

Standard Installation

Hurricane Louver Model: A520

General Notes:

1. The A520 louver system has been designed and tested in accordance with the Florida Building Code (FBC) including the HVHZ (High Velocity and Hurricane Zones) and Protocols TAS-201, 202, and 203.
2. This system has not been tested for water infiltration resistance and is not a water resistant system.
3. It shall be the responsibility of the permit holder to verify the structural integrity of the existing structure to support the loads superimposed by the louvers.
4. Maximum single panel shall be 60"W x 96"H. The louver panels may be butted together to infinite width. Single panel wide assemblies may be stacked vertically providing a structural support is designed and installed by others to support all loads transferred for the louver assembly.
5. Separation of dissimilar materials must be maintained per all applicable codes.

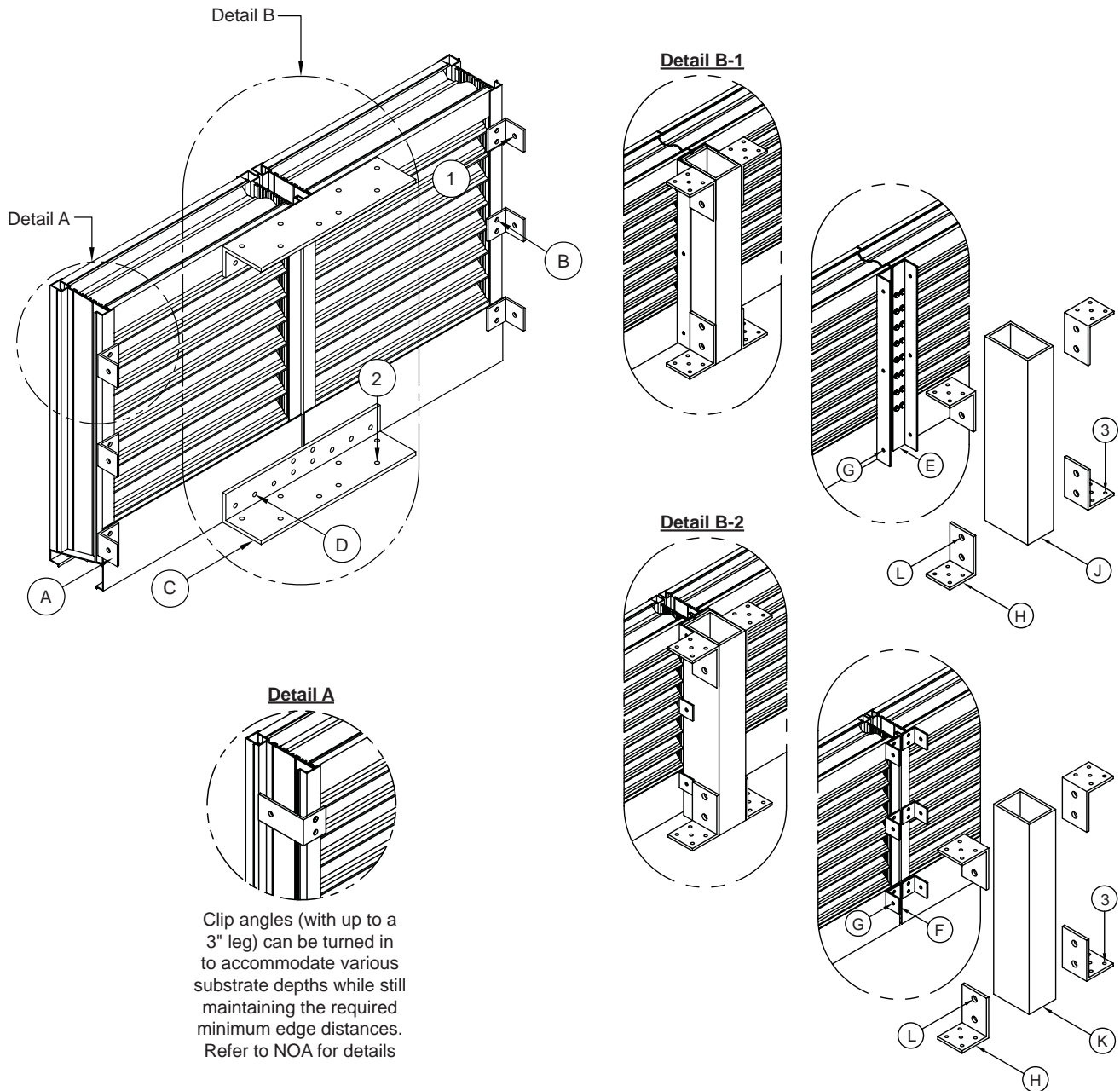

Standard Installation Hurricane Louver Model: A520

Optional Sleeve Installation

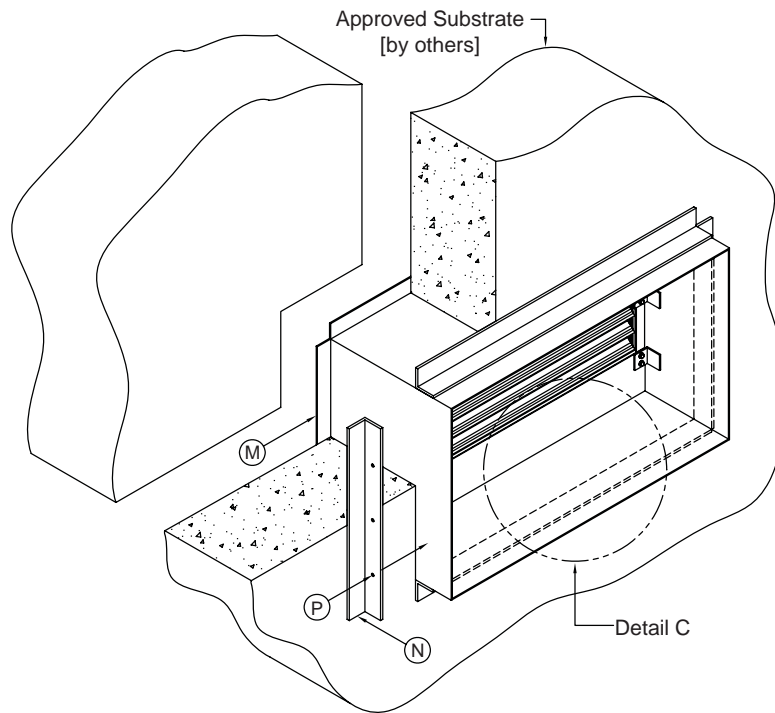

Detail C-1
Sleeve mounting Angle Fastener Pattern
with Mullion Stiffener

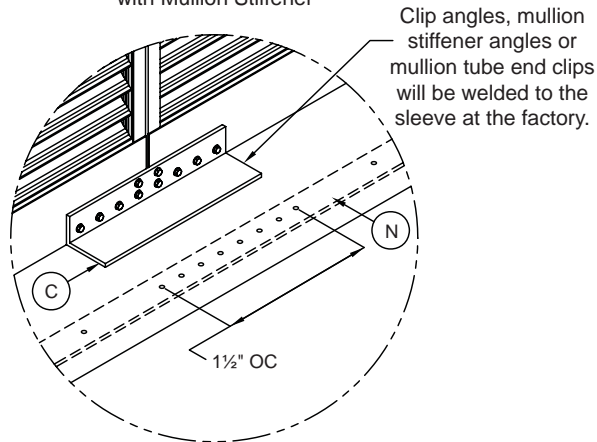

Detail C-2
Sleeve Mounting Angle Fastener Pattern
with Mullion Tube

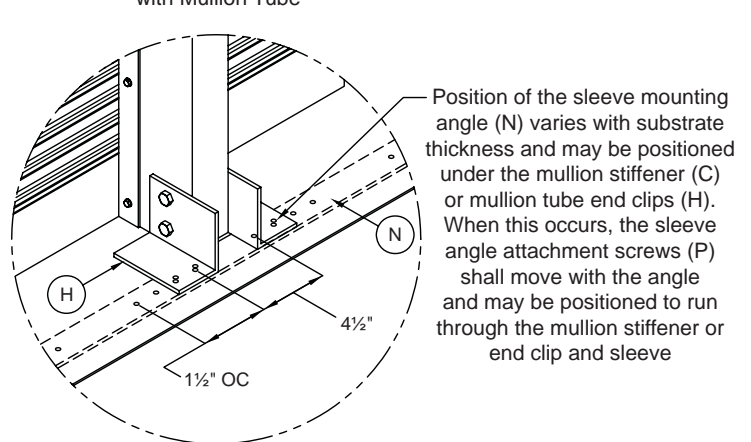

Standard Installation

Hurricane Louver Model: A520

Approved Substrates						
	Wood (1)	Metal Stud (2)	Structural Steel (3)	Aluminum (4)	Block (5)	Concrete (6)
1	W	X	X	X	Y	Y
2	W	X	X	X	-	Y
3	W (11)	X	X	X	-	Z

All Fasteners Must Be A307 Plated Steel or 304 Stainless Steel	
A	Perimeter clip mounting angle; 4" from ends max, spacing per windload requirement [provided] (7)
B	1/4-14 x 3/4" self tapping/drilling screw; 2 per clip angle [provided]
C	Mullion splice angle; 2 per standard visible vertical mullion [provided if applicable]
D	1/4-14 x 3/4" self tapping/drilling screw; 10 per splice angle [provided]
E	Full length architectural vertical mullion angle [attached at factory if applicable] (9)
F	Reinforced visible vertical mullion clip mounting angle; 5" from ends max, 8" on centers
G	1/4-14 x 3/4" self tapping/drilling screw; 8" on centers [provided]
H	Mullion tube end clip; 4 per mullion [provided with architectural or reinforced vertical mullions] (11)
J	3" x 5" x 1/4" aluminum mullion tube [provided with architectural mullions]
K	3" x 4" x 3/16" aluminum mullion tube [provided with reinforced mullions] (10)
L	1/2" x 5" A307 hex head plated or stainless steel bolt with nut and washer; 4 per mullion [provided if applicable]
M	1/8" thick aluminum sleeve with 1/2" integral flange [optional] (12)
N	2" x 2" x 1/4" Sleeve mounting angle, entire perimeter [provided if applicable]
P	1/4-14 x 3/4" self tapping/drilling screw; within 4" of corners and sleeve splices, 8" max on centers, clustered at mullions [provided if applicable] (13)
W	No. 14 SMS or wood screw, 1-3/8" min embed, 3/4" min edge distance [by others]
X	1/4-14 grade 5 self tapping/drilling screw, full embed, 1/2" min edge distance [by others]
Y	1/4" concrete screw, 1-1/2" min embed {concrete} or 1-1/4" min embed {block-sides only}, 2" min edge distance [by others] (8)
Z	1/2" Hilti stainless steel Kwick Bolt 3, 1 per angle, 3-1/2" min embed, 3" min edge distance [by others]

Notes

- (1) Wood frame or buck, minimum Grade 3 & G=0.55
- (2) Minimum 16-GA 33ksi metal stud
- (3) Minimum 1/8" thick A36 steel
- (4) Minimum 1/8" thick 6063-T5 aluminum
- (5) Minimum C-90 CMU, applicable at sides only
- (6) Minimum 3000 psi concrete
- (7) 1-1/2" x 1-1/2" (to 3" max) x 1/8" angle, 1-1/2" leg shall be secured to the louver jamb
- (8) Concrete screws shall be Elco Ultracons, ITW Ramset/Red Head Tapcons or Hilti Kwick-Con II (hardened or stainless steel)
- (9) Full length angles are optional for reinforced visible vertical mullions and/or perimeter mounting
- (10) 3" x 4" x 1/4" aluminum mullion tubes optional for higher windloads
- (11) 5 screws per angle required for wood substrate, 4 screws per angle required for all other substrates
- (12) Louvers that are able to be shipped as a single panel will be factory installed in the sleeve. If louver is a multiple panel assembly, components will be shipped loose in a 'knock-down' fashion for field assembly.
- (13) See Detail C-1 and C-2 for mullion cluster patterns

Standard Installation

Hurricane Louver Model: A520

This page intentionally left blank.