

# Standard Installation

## Multi-Blade Control and Balancing Dampers

---

### GENERAL

Upon receipt of the damper(s) at the site, inspect all items; note on Bill of Lading. Unpack all dampers carefully. Immediately note any damage and inform your representative. Do not install; it is easier to repair a damper on the floor than up in the duct.

Do not stack dampers on each other or allow debris to fall on them. Avoid rehandling if possible; install each unit as soon as possible after unpacking.

---

### DAMPER INSTALLATION

Prior to installing the damper, inspect the ductwork and surrounding area for any obstructions that might interfere with the linkage, blade rotation or actuator mounting. Care must be taken not to drop, drag, crush, or apply excessive bending twisting, racking or skewing loads upon the damper frame, blades, linkage or accessories (see fig. 1 on reverse side). Never use a chain or hook inside the damper frame for lifting, as this could damage blades, seals or frame.

- A. We recommend lubricating moving parts with dry graphite.
  - B. Manual dampers should be run through a full-open to full-close cycle by hand to insure proper operation of the damper.
  - C. Motorized dampers should be checked by a preliminary attempt to operate with the motor. If binding occurs, disconnect one end of the driving linkage (and note its exact position before-hand) to operate damper manually and check per above. Reconnect linkage and check again.
  - D. If an externally mounted operator is being utilized, a 1" diameter hole must be drilled in the duct to accommodate the operator (see fig. 4 on reverse side). Locate drive blade axle. Measure from bottom of damper to center of drive blade axle. Transfer this to wall of duct and drill 1" diameter hole.
  - E. Lift panels into duct (or opening) by its frame, not by any blade or hardware. Final position must be square, straight, plumb, and without twist (see fig. 1 on reverse side).
  - F. Due to shipping and handling, dampers may arrive at the site slightly racked or twisted. Dampers are to be squared and not twisted prior to installation into square duct or sleeves.
  - G. See fig. 2 on reverse side for attachment methods.
  - H. Damper should be shimmed in the opening to prevent distortion of the frame by the fasteners holding it in place. Dampers with seals should be caulked to prevent leakage between the frame and duct.
  - I. Check the damper for free operation.
- 

### MULTIPLE-PANEL DAMPERS

Multiple-panel dampers will be tagged for ease of assembly (see fig. 3 on reverse side or drawing C24278).

---

### OPERATORS

- A. An extended shaft kit (see fig. 4 on reverse side) is supplied if no operator is specified.
  - B. Reference specific installation instructions supplied with damper operator for motorized dampers.
  - C. Multi-panel dampers with jackshafting; See separate instructions for installation of jackshafting when not factory installed.
- 

### MAINTENANCE

In general this unit must be kept clean and free from foreign matter that may impede normal movement and seating of blades and seals (if applicable). A cleaning schedule should be established and is entirely dependent upon the environment into which the damper is placed. The damper is basically maintenance free with the above exception and regular lubrication and seal inspection as indicated below:

BEARINGS AND LINKAGE PIVOTS: Lubricate with dry graphite as required to provide free movement.

## Standard Installation Multi-Blade Control and Balancing Dampers

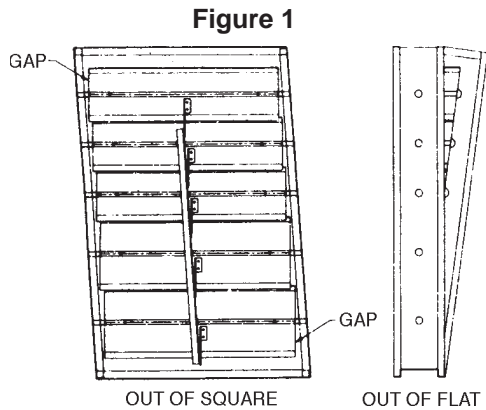

**Warning**

Improperly installed dampers and damper panels prevent the blades from sealing properly. Gaps between the blades indicate a damper installed out of flat. Out of square installations can cause damage to side seals and will also require excessive actuator torque.

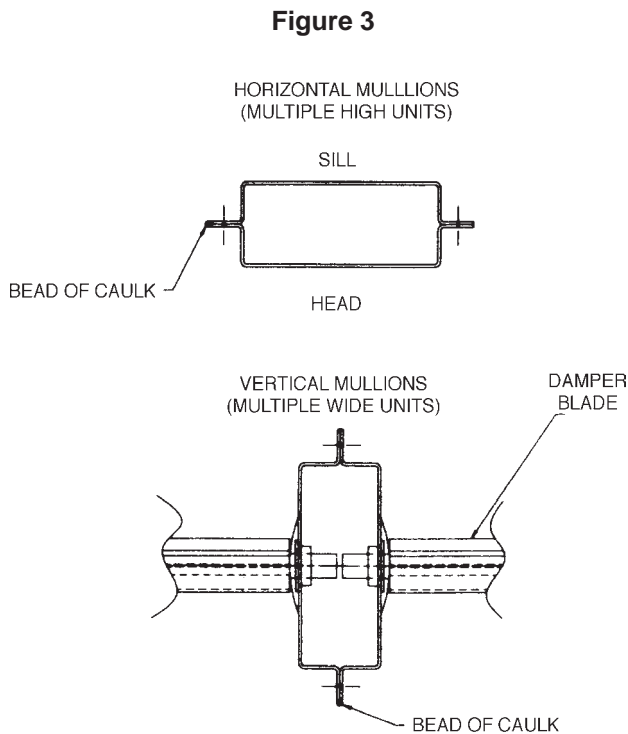
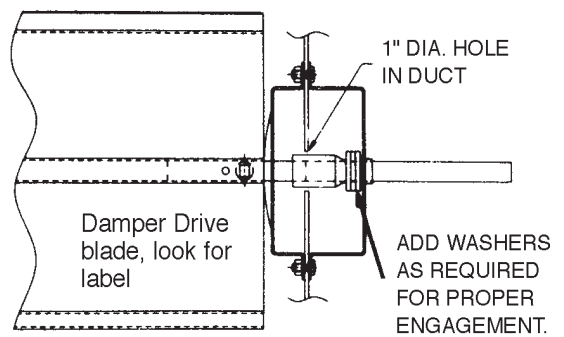
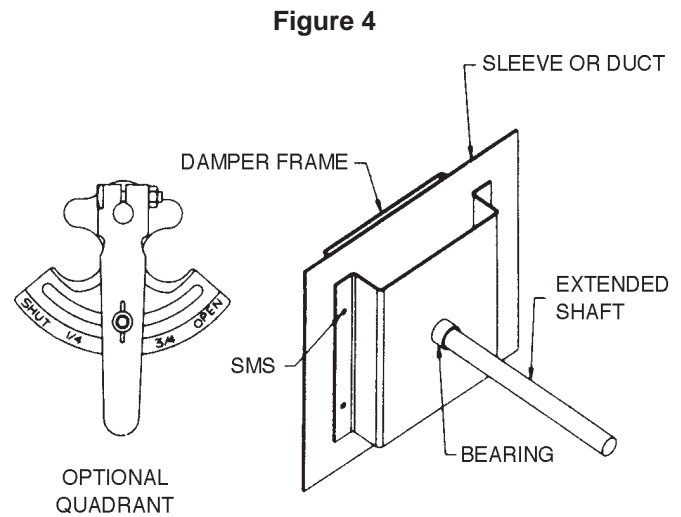
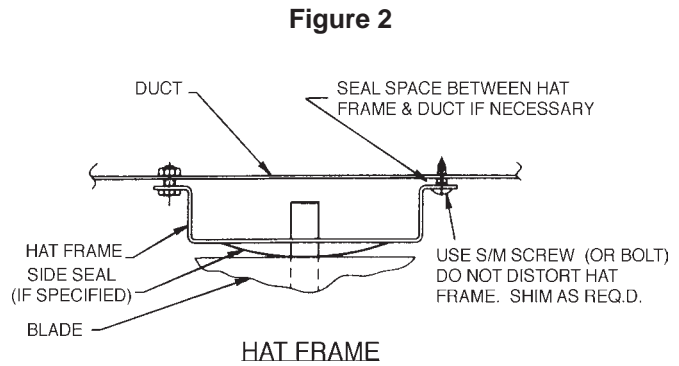

USING 1/4-20 BOLTS, WASHERS AND LOCKNUTS OR #10 SHEET METAL SCREWS, JOIN PANELS TOGETHER.

## Standard Installation Multi-Blade Control and Balancing Dampers



Pre-drill (9/16" dia. hole) in Duct at Manual Quadrant Mounting Location Where the Manual Quadrant Lever Arm is Most Accessible and Free of Rotational Restrictions

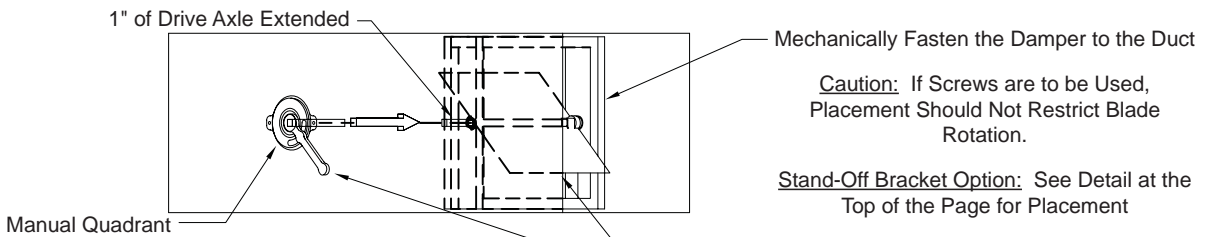
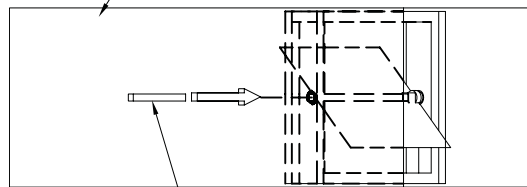
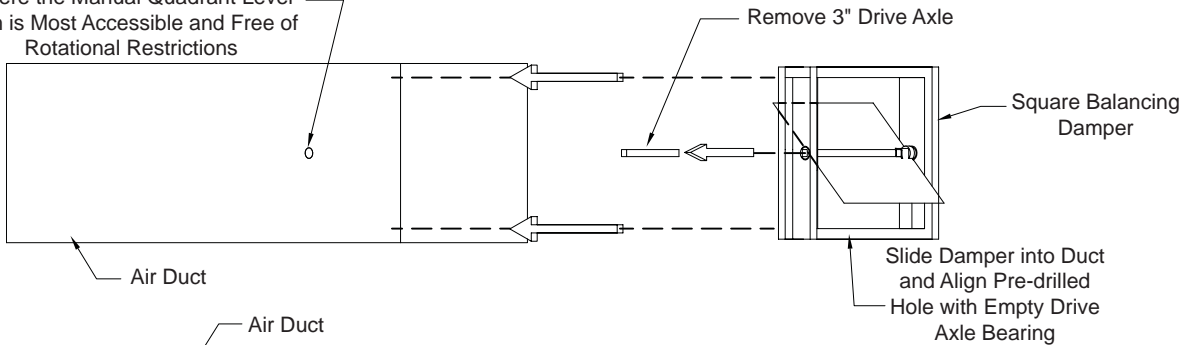

Loosen Wing Nut on the Manual Quadrant and Align Mounting Tabs Parallel to Duct Length

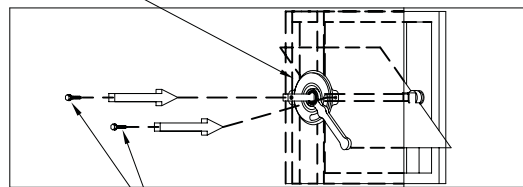

**Note:** Insure Damper is Open When Manual Quadrant Indication States Open.

**Caution:** If Screws are to be Used, Placement Should Not Restrict Blade Rotation.

# Standard Installation Multi-Blade Control and Balancing Dampers

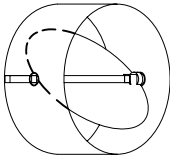

Round Balancing Damper



Manual Quadrant

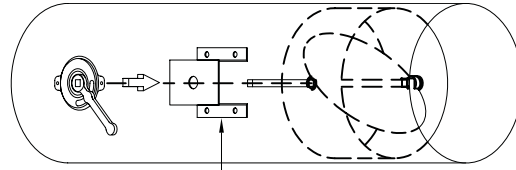

Stand-Off Bracket  
Optional Stand Off Bracket

Pre-drill (9/16" dia. hole) in Duct at Manual Quadrant Mounting Location Where the Manual Quadrant Lever Arm is Most Accessible and Free of Rotational Restrictions

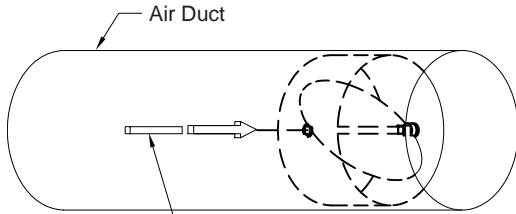
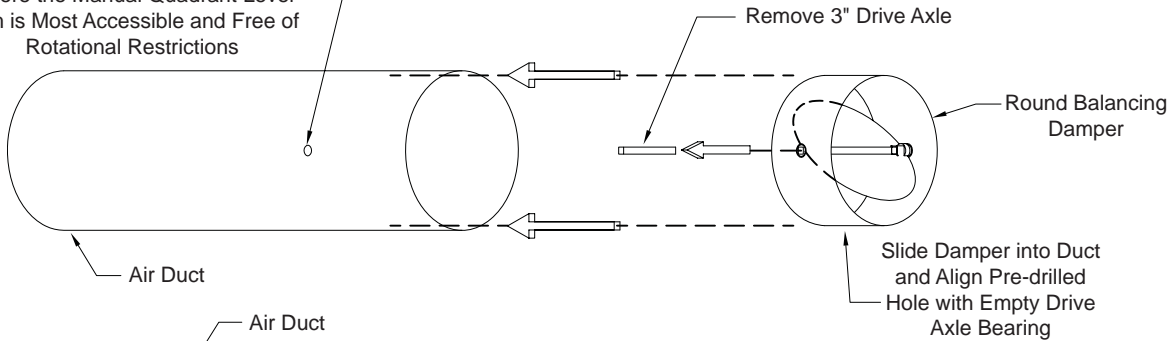

Tap 2" of the 3" Long Drive Axle Through the 9/16" Pre-drilled Hole into the Damper Bearing. This Leaves an Approximate 1" Extension of the Drive Axle for the Assembly of the Manual Quadrant.

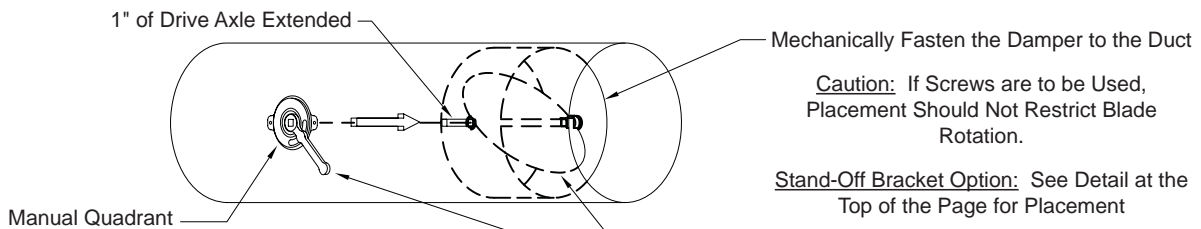

**Caution:** If Screws are to be Used, Placement Should Not Restrict Blade Rotation.

**Stand-Off Bracket Option:** See Detail at the Top of the Page for Placement

Loosen Wing Nut on the Manual Quadrant and Align Mounting Tabs Parallel to Duct Length

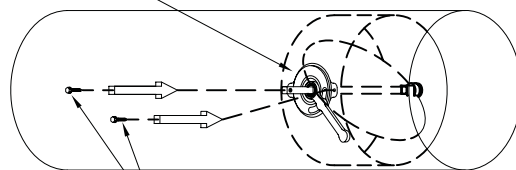

Align Manual Quadrant Lever Arm Parallel to Damper Blade and Slide Manual Quadrant onto Dive Axle.

**Note:** Insure Damper is Open When Manual Quadrant Indication States Open.

**Caution:** If Screws are to be Used, Placement Should Not Restrict Blade Rotation.