

Standard Installation

Fire & Fire/Smoke Rated Front Access (Grille Mount) Dampers

APPLICATION

This UL Classified (see complete marking on product) multi-blade fire dampers and combination fire/smoke dampers have been tested with the damper out of the plane of the fire barrier. This arrangement allows for grille and grille/OBD assemblies to be flush mounted to the face of the fire barrier. Upon removal of the grille, the damper, damper actuator, and resetting of the heat responsive device are accessible.

This damper is intended to close automatically when sensing elevated temperature or upon loss of electrical power. If closed due to loss of electrical power, the damper will reopen when electrical power is restored.

- 1½ Hour Fire Rated, UL File R4708
- For Use in Dynamic or Static Systems
- Available in UL Leakage Class I or II (Combination Fire/Smoke Models)
- Factory Mounted Sleeve and Actuator
- 15 Second (maximum) Opening Time, Actuator Regulated Closure

PANEL SIZE LIMITATIONS

		Actuation	Electric			
		Orientation	Horizontal 250° or 350°		Vertical 250° or 350°	
		Assembly	Min. Panel	Max. Panel	Min. Panel	Max. Panel
Model	FS1, GG1, MS1, AS1	16"W x 10"H	36"W x 42"H	16"W x 10"H	36"W x 42"H	
	FS2, GG2, MS2, AS2	10"W x 10"H	36"W x 42"H	10"W x 10"H	36"W x 42"H	
	FA1, CA1, MA1, UA1	12"W x 10"H	32"W x 42"H	12"W x 10"H	32"W x 42"H	
	FA2, CA2, MA2, UA2	10"W x 10"H	32"W x 42"H	10"W x 10"H	32"W x 42"H	

		Actuation	Non-Motorized			
		Orientation	Horizontal		Vertical	
		Assembly	Min. Panel	Max. Panel	Min. Panel	Max. Panel
Model	MD19, 15MD, 17MD, MD17	10"W x 10"H	36"W x 42"H	10"W x 10"H	36"W x 42"H	
	MA19, 15MA, 17MA, MA17	10"W x 10"H	32"W x 42"H	10"W x 10"H	32"W x 42"H	

Standard Installation

Fire & Fire/Smoke Rated Front Access (Grille Mount) Dampers

INSTALLATION

This damper is approved for vertical and horizontal installation. This damper can also be mounted into wood stud construction walls, **See Figure 3**. Blades must run horizontal when vertically mounted. When vertically mounted, this damper is required to be insulated on the top and two sides (the bottom is not insulated). This damper cannot be mounted up-side-down, reference "Top of Damper" label. When horizontally mounted, the damper must be mounted in a masonry/concrete floor, **See Figure 5**. The exterior of the sleeve is insulated on all four sides. Pinching, racking and other causes of frame distortion can result in reduced leakage resistance of incomplete closure.

Electrical wiring is to be in compliance with local codes and the National Electrical Code (NEC). Reference wiring diagram on damper, ensure that supply voltage matches actuator requirements. Damper and actuator must be tested prior to system start-up to ensure proper operation.

1. If the actuator is electrically energized yet the damper remains in the closed position, check that the reset button on the heat response device is depressed (disconnect power before resetting).

2. **Insulation** - The exterior of the damper sleeve is factory insulated. Care should be taken during installation to prevent ripping or other damage to the insulation.

3. **Opening Size** - No expansion clearance is required but sufficient clearance between the damper and the opening is required for the insulation and for mounting. The minimum opening width shall be $\frac{3}{8}$ " larger than the nominal width. The minimum opening height shall be $\frac{1}{4}$ " larger than the nominal height when vertically mounted. When horizontally mounted, the opening height shall be $\frac{3}{8}$ " larger than the nominal height. The maximum opening size shall be no more than $\frac{1}{4}$ " greater than the minimum opening size.

Example: An 18"W x 24"H nominal size damper, when mounted vertically, will require a minimum opening width of 18 $\frac{3}{8}$ " and a minimum opening height of 24 $\frac{1}{4}$ ". Note the preceding example is based on the standard 20-GA sleeve.

4. **Duct Mounting** - When duct work is connected to the non-flanged end of the damper sleeve, the following applies: Sleeves shall be steel of the same gauge or heavier as the duct to which it is attached. Sleeve gauge to be 20-GA min. 14-GA max. Connecting ducts shall not be continuous, but terminate at damper sleeve. Duct connections to the sleeve will be either of the breakaway or rigid types. The following determines if the connections are rigid or breakaway: For rigid type duct connections, sleeve shall be a minimum of 16-GA on dampers not exceeding 36"W or 24"H and 14-GA on larger units. The standard factory supplied sleeve is 20-GA galvanized steel and requires that a breakaway type duct connection will be employed. The following breakaway duct-to-sleeve connections may be used: Plain "S" Slip, Double "S" Slip, Inside Slip, Hemmed "S" Slip, Standing "S" Slip (Bar or Angle Reinforced), Standing "S" Slip (Alternate Bar). Various flanged connection systems are also approved as breakaway connections. Consult manufacturer's instructions for specific details.

5. **Sensotherm Reopenable Feature** - This feature allows the damper to be reopened from a remote switch (by others) after the low temperature heat responsive device has been activated.

Operation of optional reopenable (Sensotherm) feature:

A. Master Control Switch in closed position - the damper will close regardless of whether the thermal switch device has activated or not and regardless of the command from the smoke detector.

B. Master Control Switch in reopen position - if the damper has not been exposed to an elevated temperature higher than its rating, the damper will open. Also, the damper will open regardless of whether the low limit switch (either 165°F or 212°F) has actuated or not. If the damper has been exposed to an elevated temperature higher than its temperature degradation rating or if the electrical or pneumatic supply has been disconnected, the damper will close and remain closed regardless of a Master Control Switch position.

6. **Maintenance** - Damper shall be maintained in intervals as stated in NFPA 80, 90A and 92A unless local codes require more frequent inspections.

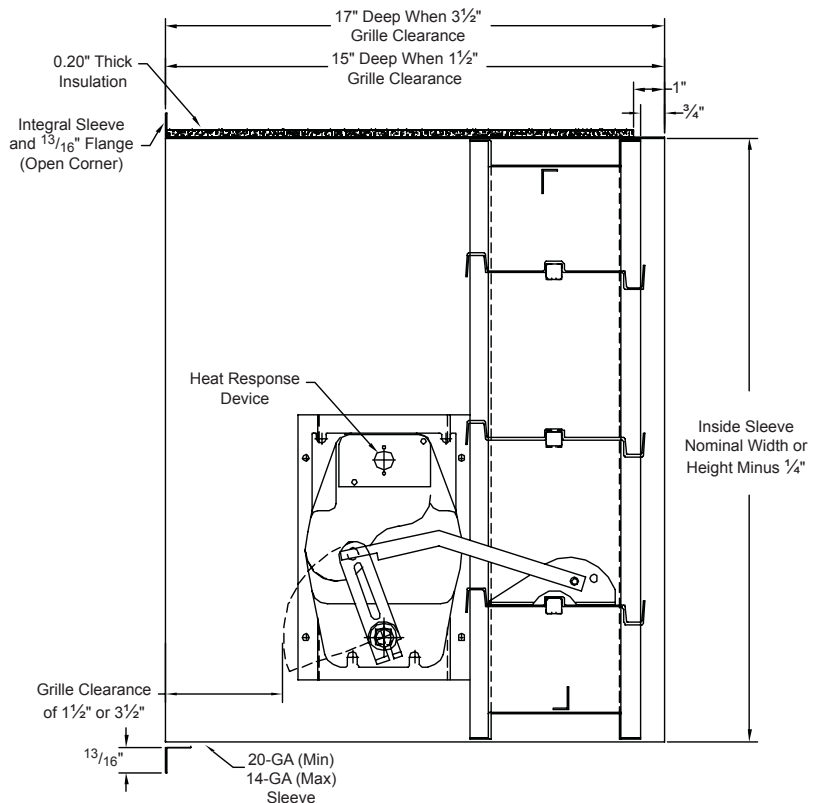

Figure 1

Standard Installation

Fire & Fire/Smoke Rated Front Access (Grille Mount) Dampers

Metal Stud or Masonry Wall Construction

In addition to the previously stated General Requirements, the following instructions pertain to block, masonry or metal stud construction. **See Figure 2 and Figure 5.**

7. **Grille** - A minimum 26-GA steel frame is required, core of grille can be aluminum or nonmetallic. If a thinner or non-steel grille frame is used, the open corners of flanged sleeve must be closed off with 20-GA minimum corner tabs (by others) riveted to flanges. When the flanges are not continuous but formed by a series of flange clips, grille flange must be steel of a minimum thickness of 26-GA. **See Figure 4.**

8. **Mounting Damper to Opening** - Unlike traditional fire damper installations, this damper requires no perimeter retaining angles. To mount the damper, insert the damper into the opening until the flange contacts the wall face, **See Note 3** for proper opening sizing. Through the grille clearance area of the sleeve, secure the damper to the steel wall stud framing using #10 steel S.M.S. 12" O.C. (maximum), 6" (maximum) from each corner, minimum of one fastener per each side, bottom and top. For masonry construction, use #10 x 1¼ (minimum) steel concrete screws or anchors (same spacing as for steel stud construction). Follow masonry anchor manufacturer's recommendations for minimum distance from edge.

Wood Stud Wall Construction

In addition to the previously stated General Requirements, the following instructions pertain to wood stud construction walls. **See Figure 3.**

9. **Grille** - A minimum 26-GA steel frame is required, core of grille can be aluminum or nonmetallic. If a thinner or non-steel grille frame is used, then open the corners of flanged sleeve must be closed off with 20-GA (minimum) corner tabs (by others) riveted to flanges. Grille is attached to either the sleeve flange or to the wood framing with steel screws 10" maximum on center.

10. **Mounting** - The damper is retained in the opening by the front sleeve flange and rear retaining angles. Rear perimeter retaining angles to be a minimum size of 1½" x 1½" x 16-GA steel or Mestek CDLG supplied 1½" x 7⁄8" x 16-GA steel "Tab-Lock" retaining angles. Angles are attached to the damper sleeve using #10 steel sheet metal screws of 13⁄16" steel rivets at 6" maximum on-center.

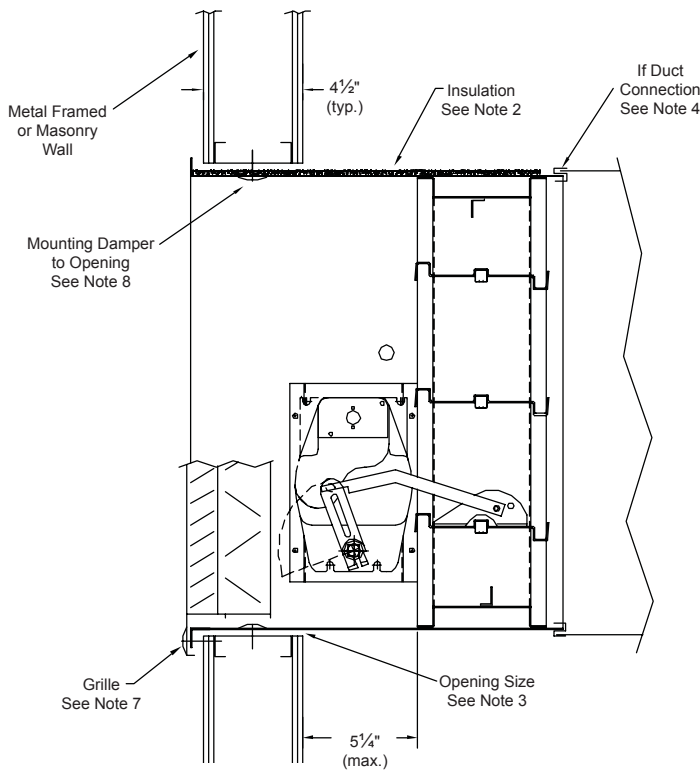

Figure 2

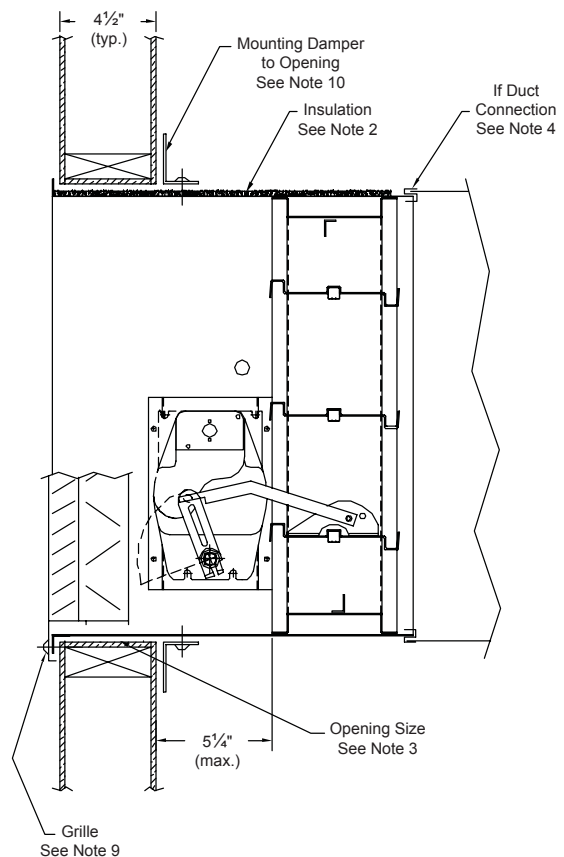

Figure 3

Standard Installation

Fire & Fire/Smoke Rated Front Access (Grille Mount) Dampers

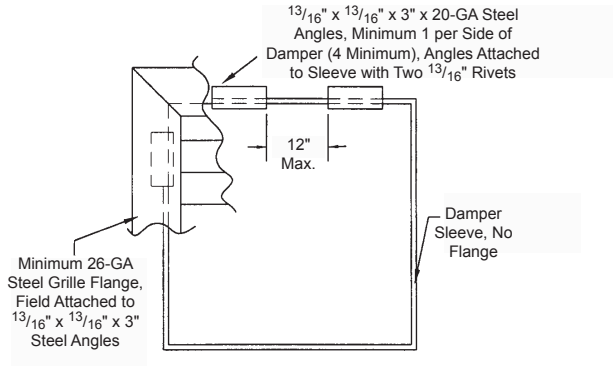
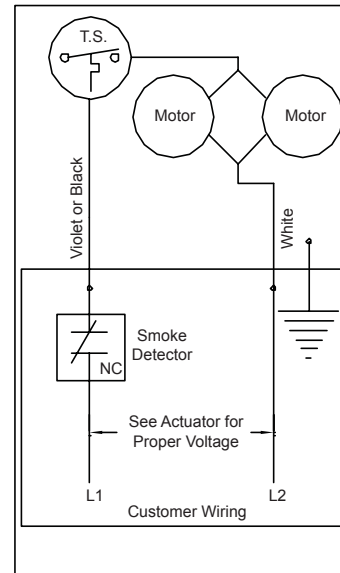
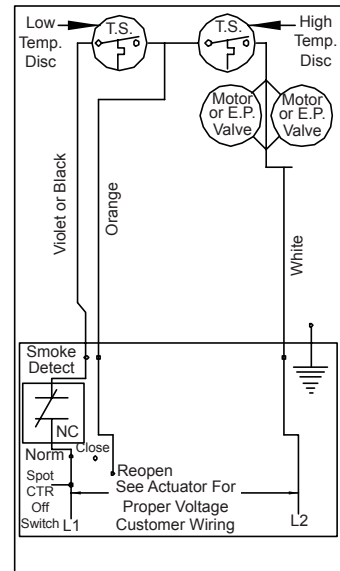

Figure 4

Un-Flanged Sleeve, Damper Above Floor Plane



For use on dampers with one heat response device (non-reopenable).



Damper with two heat response devices (reopenable).

Wiring Schematic

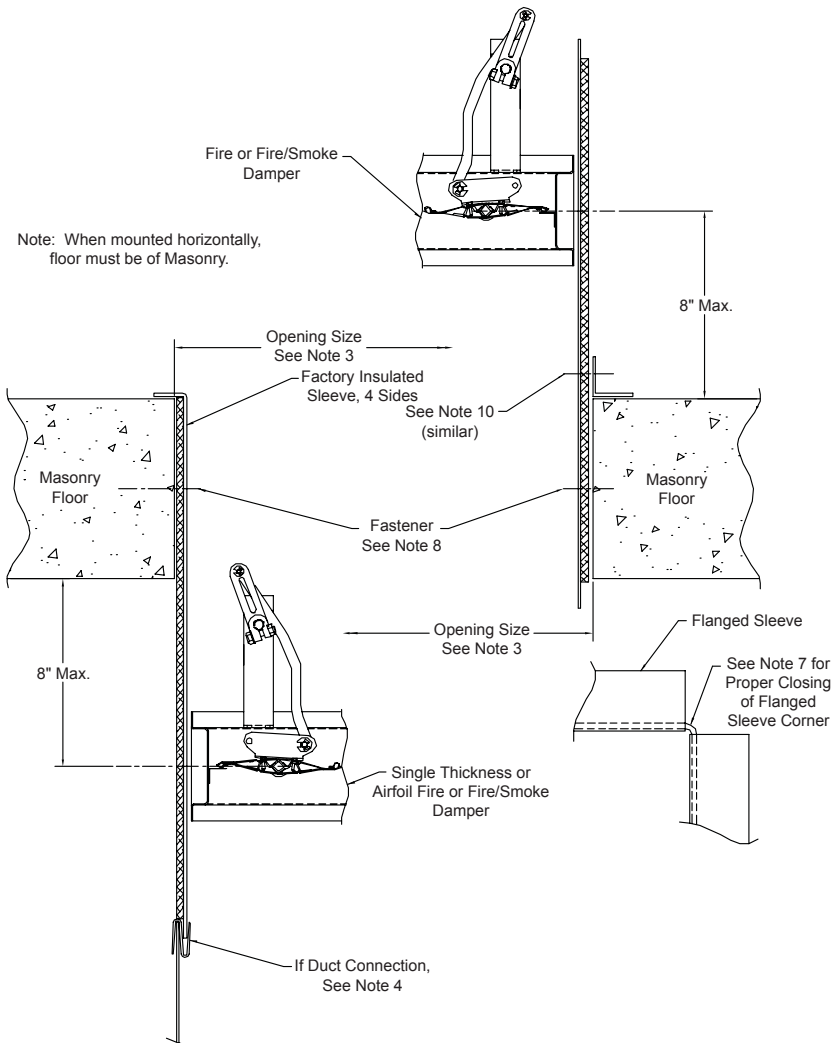

Flanged Sleeve, Damper Below Floor Plane

Figure 5