

# Standard Installation

## Fire Damper Model: RF

## Fire/Smoke Damper Model: RC

## Smoke Damper Model: RS

### APPLICATION

Damper Models RC and RF are round, single blade, dynamically rated combination fire/smoke and fire dampers are intended to restrict the passage of flame and smoke (Model RC) or flame only (Model RF). These dampers are to be mounted such that the closed plane of the damper blade is within the fire barrier. Airflow can be from either direction. When mounted in the vertical position the damper may be mounted right side up or upside down.

Damper Models RC and RF can be mounted horizontally in a round or square masonry/concrete floor opening with its jackshaft/actuator assembly on the topside of the floor. Damper can be mounted vertically in a round or square masonry/concrete wall opening as well as in square metal or wood framed gypsum board wall openings. When mounted vertically, the damper's axle can vary by as much as 30° from the horizontal.

Damper Model RS is a dynamically rated smoke damper that can be mounted horizontally or vertically. Airflow can be from either direction. When mounted in the vertical position the damper may be mounted right side up or upside down. When mounted vertically, the damper's axle can vary as much as 30° from the horizontal. It can be mounted within the plane of the smoke barrier as well as mounted outside of the plane of the smoke barrier. When mounted outside of the plane of the smoke barrier it is to be installed within 24" of the barrier and before any duct inlets or outlets.

### PANEL SIZE LIMITATIONS

Model	Mounting	Min Diameter	Max Diameter	Ratings
RC	Vertical or Horizontal	6" dia.	24" dia.	1½ Hour, UL555 Rated Leakage Class I, 250°F or 350°F (depending on actuator selected), UL555S Rated
RF	Vertical or Horizontal	8" dia.	24" dia.	1½ Hour, UL555 Rated
RS	Vertical or Horizontal	6" dia.	24" dia.	Leakage Class I, 250°F or 350°F (depending on actuator selected), UL555S Rated

### SUPPLEMENTAL INSTALLATION INSTRUCTIONS / SUBMITTAL DATA

Electric or Pneumatic Heat Response Device (SD-EHRD or SD-PHRD)  
 Integral Dual Position Indication (SD-IDPI)  
 Electric or Pneumatic Sensotherm (SD-ESOT or SD-PSOT)

# Standard Installation

Fire Damper Model: RF  
 Fire/Smoke Damper Model: RC  
 Smoke Damper Model: RS

## INSTALLATION REQUIREMENTS FOR MODEL RC AND RF

1. The 20-GA (minimum) galvanized steel retaining plate can be factory or field supplied, see Figures 4A and 4B for details. Retaining plate(s) to overlap the opening by a minimum of 1.0" on each of the four sides. See Figures 1, 2, and 3 for type of retaining plate-to-opening steel fastener to use.
2. A second retaining plate is optional when mounting into masonry/concrete or metal framed gypsum board constructions. A second retaining plate is required when mounting into wood framed gypsum board construction. When a second retaining plate is used on the non-actuator side, it is attached to the damper sleeve with 1" x 1" x 20-GA by ½ long (minimum) clip angles. Clip angles attached to damper sleeve with a single #10 steel SMS on 14" maximum centers, minimum three equally spaced. No plate-to-face of opening fasteners required for this second plate. Fastener placement must not interfere with damper blade travel.
3. The clearance between the opening and the damper sleeve is to be a minimum of 1" and a maximum of 2.5". Damper can rest on the sill of the opening with all of the expansion clearance at the top of the opening. Regardless of how the damper is positioned in the opening, the retaining plate must overlap the opening by a minimum of 1" on each of the four sides.
4. When vertically mounted, damper axle should be as horizontal as possible but can be as much as 30° above or below the horizontal.
5. Any connecting ducts shall not be continuous and shall terminate at the damper sleeve. Duct connections are made with a 4" wide draw-band connection or #10 SMS. When the duct is attached to the damper sleeve with SMS; 3 equally spaced screws for 22" and smaller diameters, 5 equally spaced screws for larger diameters. See Note 1 below. If the duct to damper sleeve connection is to be caulked, use either Design Polymeric's DP1010 or Precision's PA2084T.
6. The damper sleeve shall not extend more than 6" beyond the fire barrier on the non-actuator/jackshaft side nor more than 16" on the actuator/jackshaft side.
7. When mounted horizontally in a floor, actuator/jackshaft to be on the topside.
8. Dampers shall be maintained at intervals stated in NFPA 90S and 92A. Local codes or building conditions may require more frequent inspections and maintenance. A duct access door is to be located on the jackshaft side of each damper for periodic inspection and maintenance.

## NOTES

1. Damper can also be connected to ductwork using draw band or slip connection.

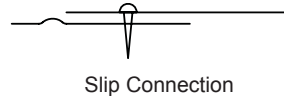
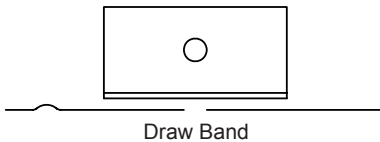

# Standard Installation

Fire Damper Model: RF  
 Fire/Smoke Damper Model: RC  
 Smoke Damper Model: RS

## Mounting in Round or Square, Masonry/Concrete

**Figure 1**

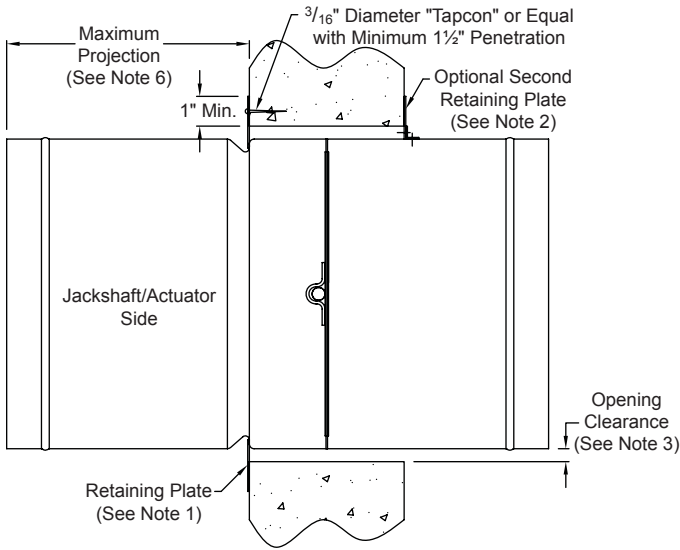

## Mounting in Square, Metal-Framed Gypsum Board

**Figure 2**

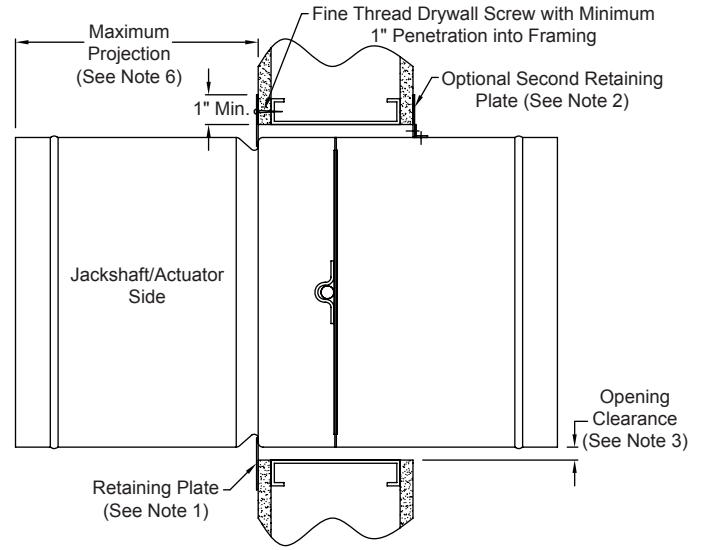

## Mounting in Square, Wood-Framed Gypsum Board

**Figure 3**

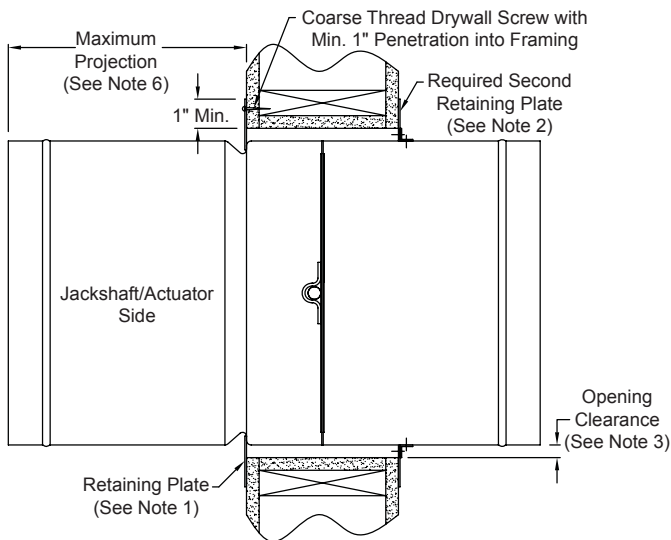

## Damper Retaining Plates

**Figure 4A**

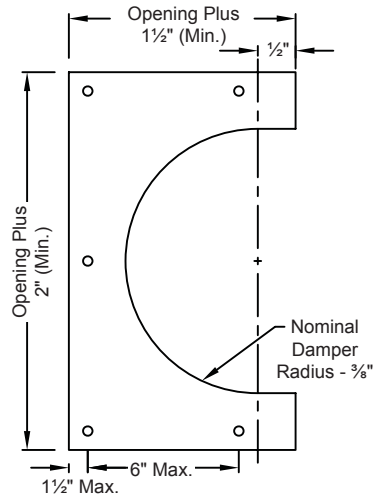

**Figure 4B**

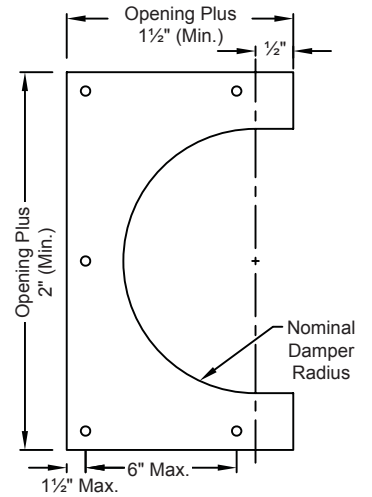

Actuator Side Plate  
 - Two Halves Required  
 - 20-GA Galvanized Steel  
 - Nests into Frame Groove

Non-Actuator Side Plate  
 - Two Halves Required  
 - 20-GA Galvanized Steel  
 - Slides Over Frame



Dampers Louvers  
 UL Life Safety Products

# Standard Installation

Fire Damper Model: RF  
 Fire/Smoke Damper Model: RC  
 Smoke Damper Model: RS

**Smoke Only, Vertical or Horizontal**  
**Figure 5**

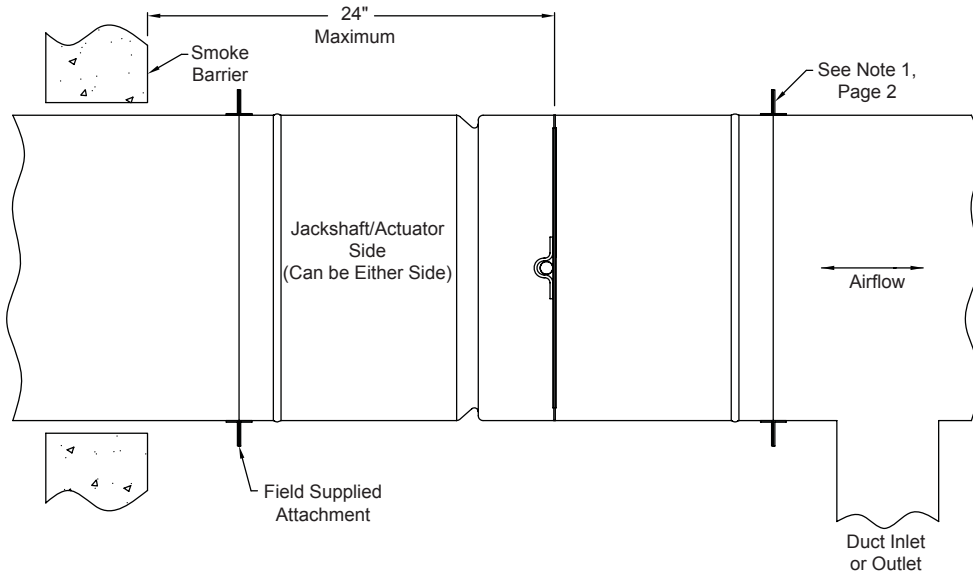

## ELECTRIC WIRING SCHEMATICS

**Notes**

1. All wiring to be in accordance with N.E.C. (NFPA 70).
2. Refer to actuator label for appropriate voltage.
3. Connect incoming ground to the actuator assembly.
4. If the actuator remains electrically energized, yet the damper remains in the closed position, check to ensure that the reset button on the heat response device is depressed.

**Electric Heat Response Device (EHRD)**  
**Figure 6A**

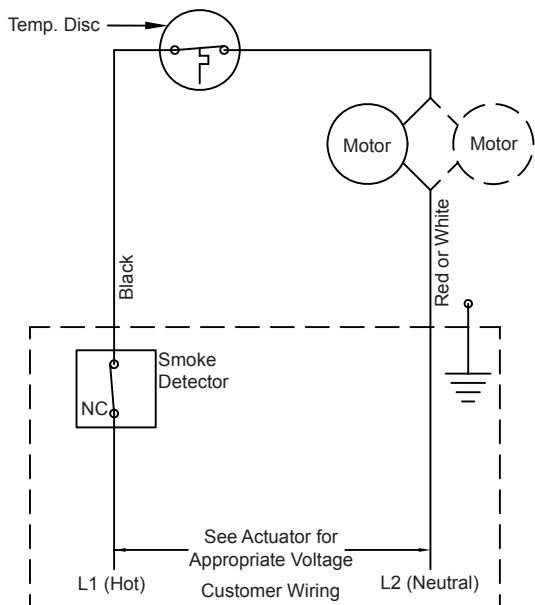

**Integral Dual Position Indication (IDPI)**  
**Figure 6B**

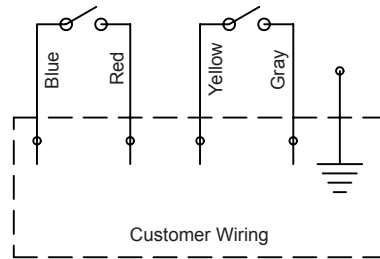

Integral Dual position Indication (IDPI) Wiring Chart			
Actuator Mounting Location	Damper Full Open	Damper Full Close	Damper Mid-Stroke
	Closed Circuit		
External Left	Red/Blue	Yellow/Gray	None
External Right	Yellow/Gray	Red/Blue	None

\*This wiring is opposite if the actuator is rotated 90°, so that it is parallel to the duct.

# Standard Installation

Fire Damper Model: RF  
 Fire/Smoke Damper Model: RC  
 Smoke Damper Model: RS

## ELECTRIC WIRING SCHEMATICS (CONT.)

### Electric/Pneumatic Sensotherm (ESOT/PSOT) with included Integral Dual Position Indication (IDPI)

**Figure 6C**

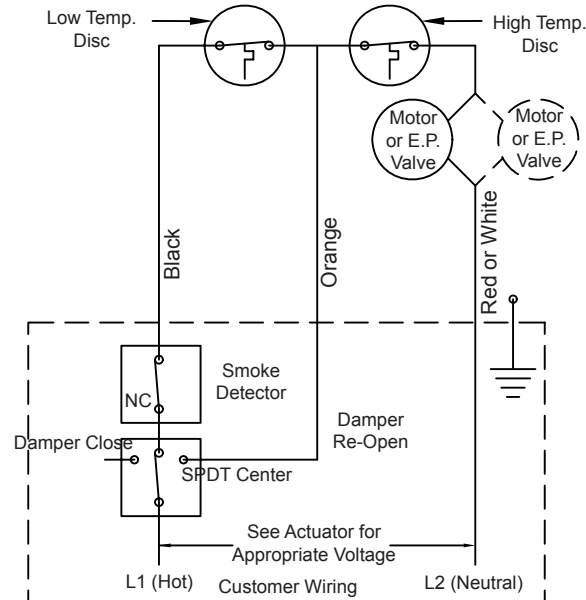

#### ESOT/PSOT Wiring, Test, and Operating Instructions

Damper is supplied with one low temperature thermal disc and one high temperature thermal disc. All dampers require a control switch (supplied by others) for re-openable operation.

#### Customer Wiring

1. Connect input power lead L1 from the normal closed position lead of the (MCS) switch to damper lead L1.  
 Note: If a smoke detector or other sensing device is to be employed, its NC contact set should be wired in series between the (MCS) position switch normal wire and lead L1.
2. Connect incoming lead L2 to damper lead L2.
3. Connect the reopen switch lead from (MCS) to orange damper lead.
4. Connect the incoming ground lead to the wiring enclosure.
5. Install IDPI (if used) per the schematic.
6. Replace enclosure cover.

#### Circuit Test

1. Place (MCS) switch in damper close position.
2. Apply power.  
 Result: The closed indicator light (if used) should be on and the damper blades closed.
3. Transfer (MCS) switch to damper re-open position.  
 Result: The damper blades should open; the closed indicator light (if used) should go off and the open indicator light (if used) should go on.
4. Transfer (MCS) switch to the normal position.  
 Result: The damper blades should remain open and the open indicator light (if used) should remain on.
5. Transfer the (MCS) switch to the closed position.  
 Result: The damper blades should close; the open indicator light (if used) should go off and the closed indicator light (if used) should go on.

#### Emergency Operation (Smoke Management)

1. MCS Closed Position: Damper will close regardless of whether the thermal switch device has activated or not and regardless of the command for the smoke system.
2. MCS Re-Open Position: If the damper has not been exposed to an elevated temperature higher than its rating, the damper will open. Also, the damper will open regardless of whether the low temperature thermal disc (165°F or 212°F) has activated or not and regardless of a command from additional sensing devices, such as a smoke detector.

Note: If the master control switch (MCS) is in the re-open position and the high temperature thermal disc has not been tripped, the damper will remain open regardless of whether the low temperature thermal disc and/or other sensing devices have tripped or not. If the damper has been exposed to an elevated temperature higher than its temperature degradation rating, or if the electrical or pneumatic supply has been disconnected, the damper will close and remain closed regardless of any (MCS) position.

# Standard Installation

Fire Damper Model: RF  
 Fire/Smoke Damper Model: RC  
 Smoke Damper Model: RS

## UL CLASSIFIED FIRE DAMPERS INSTALLED INTO METAL OR WOOD FRAMED 1 HOUR AND 2 HOUR RATED DRYWALL PARTITIONS

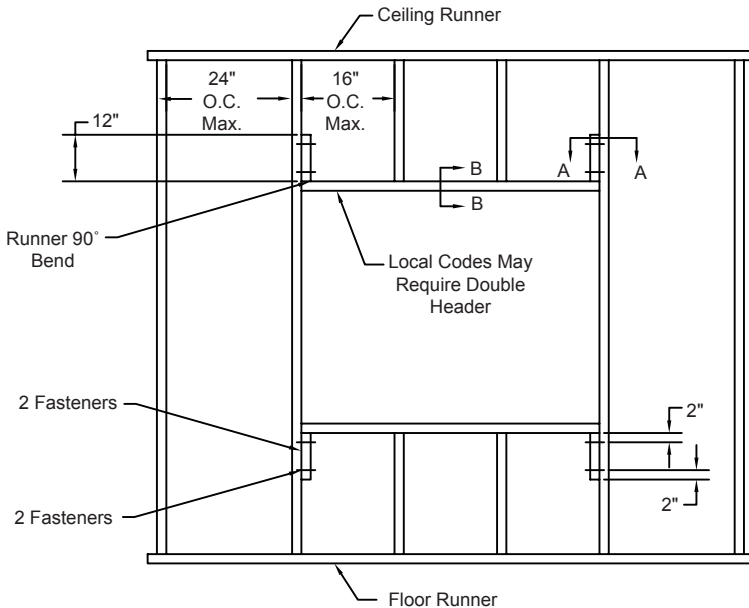

### Section A-A

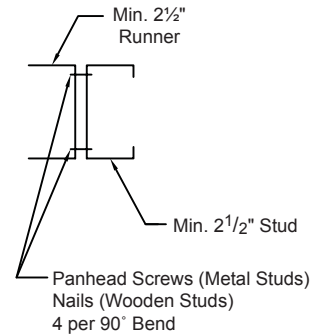

### Section B-B (1 Hour Rated Fire Barrier)

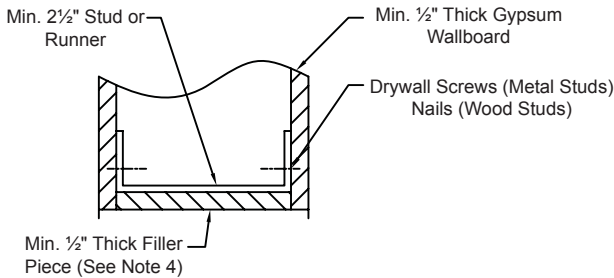

### Section B-B (2 Hour Rated Fire Barrier)

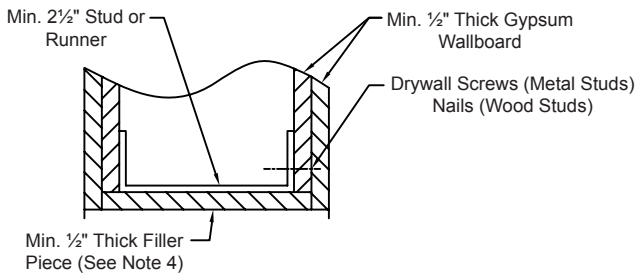

### NOTES:

1. These illustrated partition designs have successfully been tested in conjunction with 1½ hour classified fire dampers, for additional designs, reference Underwriters Laboratories, Inc. Fire Resistance Directory. Specific framing requirements of openings may vary with the Local Authority that has jurisdiction. Specific framing requirements should be provided in the architectural and structural drawings.
2. Reference the damper's installation instructions regarding the approved method of attaching the retaining angles/mounting plates, required expansion clearances, etc. Type of framing does not affect the stated required expansion clearance.
3. Gypsum panels surrounding the opening are to be fastened to all stud and runner flanges, 12" o.c. maximum.
4. When wooden studs are used, filler pieces must be installed around the entire opening. Filler pieces are optional when metal studs are used (consult local codes to determine if filler pieces are required). Filler pieces are to be double screwed (or nailed to wooden studs) on 12" maximum centers to the web of runners and studs.
5. Some jurisdictions require filler pieces around both wood and metal framed openings (no filler pieces around concrete or masonry openings). These codes may also require a double header for wood framed openings, consult local code authorities.