

Standard Installation

Duct Smoke Detectors Mounted on Combination Fire/Smoke or Smoke Dampers

ASSEMBLY APPROVAL

Underwriters Laboratories Inc. does not have a separate Product Category for factory mounted dampers/smoke detector assemblies. Individually the smoke detector and the damper have been evaluated by their applicable UL Standards. It is the responsibility of the Local Authority Having Jurisdiction to determine the appropriateness of the smoke detector/damper assembly taking into consideration design velocities during an incident condition and obstructions/duct fittings in proximity of the smoke detector.

PURPOSE OF DUCT SMOKE DETECTION

National and local safety standards and codes recognize the ability of air duct systems to transfer smoke, toxic gases, and flame from area to area. Sometimes smoke can be of such quantity as to be a serious hazard to life safety unless blowers are shut down and dampers are actuated. The primary purpose of duct smoke detection, then, is to prevent injury, panic, and property damage by reducing the spread (recirculation) of smoke. Duct smoke detection can also serve to protect the air conditioning system itself from fire and smoke damage. Consult NFPA90A, NFPA72 and Local Codes to determine where smoke detectors are required.

To avoid stratification, detector placement should be such that there is a uniform airflow through the duct. Per NFPA72, detectors should be at least six duct widths downstream from any duct openings, sharp bends or branch connectors.

DAMPERS AVAILABLE

The smoke detector models listed below can be provided with any of the following combination fire/smoke dampers or smoke dampers:

Single Thickness & Airfoil Bladed,
 1½ & 3 Hour Rated Fire/Smoke,
 Corridor Fire/Smoke,
 Airfoil & Single Thickness Smoke Only Models

The detector can be provided one of two different ways. The detector can be factory mounted to the sleeve of the damper and factory wired to the damper actuator. When factory wired, the damper will travel to the "fail" position when the detector senses smoke (electrical power disconnected). The detector can also be factory mounted to the sleeve of the damper but not wired to the damper actuator. **NOTE:** Model 2151 must be factory wired.

DUCT DETECTORS AVAILABLE

Two models of detectors are offered, each with specific application requirements.

Damper Type	Minimum Sleeve Depth
Fire/Smoke	19"
Smoke	18"
Grille Access Riser	16" (with 1½" Setback)
	18" (with 3½" Setback)
Corridor	16¼" (with 1¾" Setback)
	17½" (with 3" Setback or with no ¾ Flanges)
Note: Additional sleeve length added to actuator (detector) side.	

Minimum Damper Height	
No Flow Rated 2151	12"*
Flow Rated SMP501‡	10"*

*14" when internal actuators.
 ‡Optional Shipped Loose SMP501
 Has No Min Height Restriction.

Standard Installation

Duct Smoke Detectors Mounted on Combination Fire/Smoke or Smoke Dampers

External Duct Mounted -- Model SM-501P

This photoelectronic detector mounts externally to the damper sleeve with intake and exhaust sampling tubes penetrating into the airstream. This detector is recommended for ducts, 6" and wider with duct velocities within the 500 fpm to 4000 fpm range. Since this smoke detector is not rated for use at velocities below 500 fpm, local code may require an alternate means of damper closure such as zone detection or automated damper closure when the system fan is shut down. The Local Authority Having Jurisdiction should be consulted prior to the installation of the damper and smoke detector. For proper air sampling, duct pressure should be a minimum of 0.01 inches of water. Standard location when factory mounted will be on the side opposite the damper actuator. The inlet sampling tube is to be located between blades to avoid blockage of the airflow past the tube. If the detector is to be mounted on the actuator side then a longer damper sleeve must be specified at time of order. **NOTE:** The damper sleeve can extend no more than 16" beyond the face of the fire barrier. Inlet sampling tube length and orientation are critical for proper functioning. The inlet holes in the sampling tube must face into the airflow. The orientation of the inlet tube can be easily site rotated for proper airflow orientation.

Inlet Sampling Tube Length Requirements:

- A. The inlet sampling tube must span the duct width. Duct widths must be known at time of order to insure that the proper length of inlet sampling tube will be provided. See table below for appropriate sampling tube part number.
- B. Insure that the red end cap is installed in the end of the inlet sampling tube.
- C. For tubes longer than the width of the duct, the tube should extend out of the opposite side of the duct. Trim the tube so two inches maximum extend outside of the duct with the extended end plugged and tape close any holes in the protruding section of the tube.

GENERAL DESCRIPTION/SPECIFICATIONS

- Type: Photoelectronic SM-501-P
- Velocity Range: 500 - 4000 fpm
- Operating Temp Range: 32°F to 140°F
- Operating Humidity Range: 10% to 85% R.H.
- Nominal Voltage: 230 VAC 50-60 Hz., 115 VAC 50-60 Hz.,
24 VDC 50-60 Hz., 24 VAC 50-60 Hz.
- Contact Ratings: Alarm: 2 Sets of Form "C" Rated @ 10 Amps @ 115 VAC
Trouble: 1 Set of Form "C" Rated @ 10 Amps @ 115 VAC
- Agency Listings: UL268A; UROX. S2839
MEA Listed: 73-92-EX; Vol. 20
CSFM 3240-1004:108

ADDITIONAL INFORMATION

Reference smoke detector manufacturer's instructions packaged with each detector for specific wiring instructions, maintenance and testing information. The model SM-501-P detector housing cover must be securely fastened to complete the air-tight enclosure for proper air sampling.

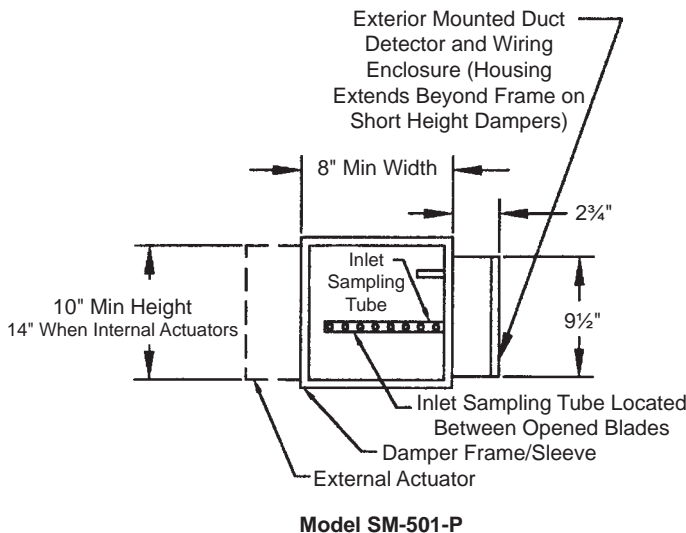

Duct Width	Inlet Sampling Tube Model
6" - 12"	STS - 1.0
12" - 30"	STS - 2.5
30" - 60"	STS - 5.0
60" - 120"	STS - 10.0

Standard Installation

Duct Smoke Detectors Mounted on Combination Fire/Smoke or Smoke Dampers

Internal Duct Mounted -- Model 2151

This photoelectric detector mounts internally within ducts. Since this detector is mounted within the duct, NFPA requires that means must be provided to monitor and test this detector from outside of the duct. To accomplish this requirement, a remote test station (Model RTS451) and a remote test coil kit (Model RTC100) are provided, reference separate instructions and the wiring schematic contained within this booklet. Duct velocity can range from 0 - 3000 fpm. For ducts wider than 18" with velocities less than 500 fpm, it is recommended that multiple detectors 18" maximum on center be installed. Standard location when factory mounted will be the top inside of the damper sleeve.

GENERAL DESCRIPTION/SPECIFICATIONS

Type:	Photoelectric
Velocity Range:	0 - 3000 fpm
Operating Temp Range:	32°F to 120°F
Operating Humidity Range:	10% to 93% R.H.
Nominal Voltage:	120 VAC (Requires Base No. B114LP)
Remote Testing:	Requires Remote Test Station RTS451 and Remote Test Coil Kit RTC100 for Each Model 2151 Detector
Contact Ratings:	See Information Provided with Each Detector
Agency Listings:	UL268A; File S911 (N) (Requires Remote Test Coil) RR 8281 (City of Los Angeles) CSFM 7272-1209:159

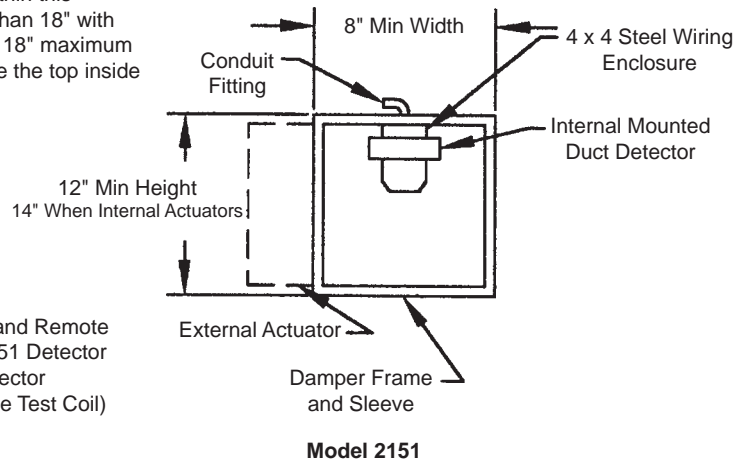

ADDITIONAL INFORMATION

Reference smoke detector manufacturer's instructions packaged with each detector for specific wiring instructions, maintenance and testing information.

TEST AND MAINTENANCE

Reference smoke detector manufacturers' instructions on field testing and recommended/required maintenance.

ADDITIONAL INSTALLATION REQUIREMENTS

These devices will not operate without electrical power. The Model SM-501-P detector housing is not weather proof and if specified, requires the WP-1 NEMA 3R weatherproof enclosure. Location of the detector must not interfere with the movement of the damper blades or the damper linkage. All wiring must be installed in compliance with the National Electrical Code and the local codes having jurisdiction. For signal wiring (the wiring between detectors or from detectors to auxiliary devices), it is usually recommended that single-conductor wire be no smaller than 18 AWG. The detector terminals accommodate wire sizes up to 14 AWG. When a smoke detector is controlling a damper driven with a pneumatic actuator, the pneumatic actuator must be controlled by an E/P valve (solenoid).

MAINTENANCE AND SERVICE OF DUCT DETECTORS

Smoke detectors are designed to be as maintenance free as possible. However, dust, dirt and other foreign matter can accumulate inside a detector and change its sensitivity; this is especially true with duct type smoke detectors. They can become more sensitive, which may cause unwanted alarms, or less sensitive, which may reduce the level of protection. Both are undesirable. Therefore, detectors should be tested periodically and maintained at regular intervals. Refer to Section 4-3 and Appendix B of NFPA-90A, Chapter 7 of NFPA 72E.

TYPICAL MAINTENANCE PRACTICES

Each installation location must be assessed on its own merits. If the protected area is of a very dirty nature, then the duct units will have to be checked and cleaned on a quarterly basis or when cleaning is required. As a guideline, the detector head should be cleaned every six months or as required. Notify the proper authorities that the smoke detector system is undergoing maintenance, and therefore the system will be temporarily out of service. **CAUTION:** Disable the zone or system undergoing maintenance to prevent unwanted alarms and possible dispatch of the fire department. The methods of cleaning are to vacuum the detector head thoroughly or to blow the detector head out using compressed air. Do not use chemicals to clean the detector head as this could contaminate the detector head and damage the casing. Sampling tubes must be inspected and cleaned in accordance with the schedule as determined above, to allow the free flow of air through the sensing tube. Reference instructions packaged with each detector for specific maintenance and testing information.

Standard Installation

Duct Smoke Detectors Mounted on Combination Fire/Smoke or Smoke Dampers

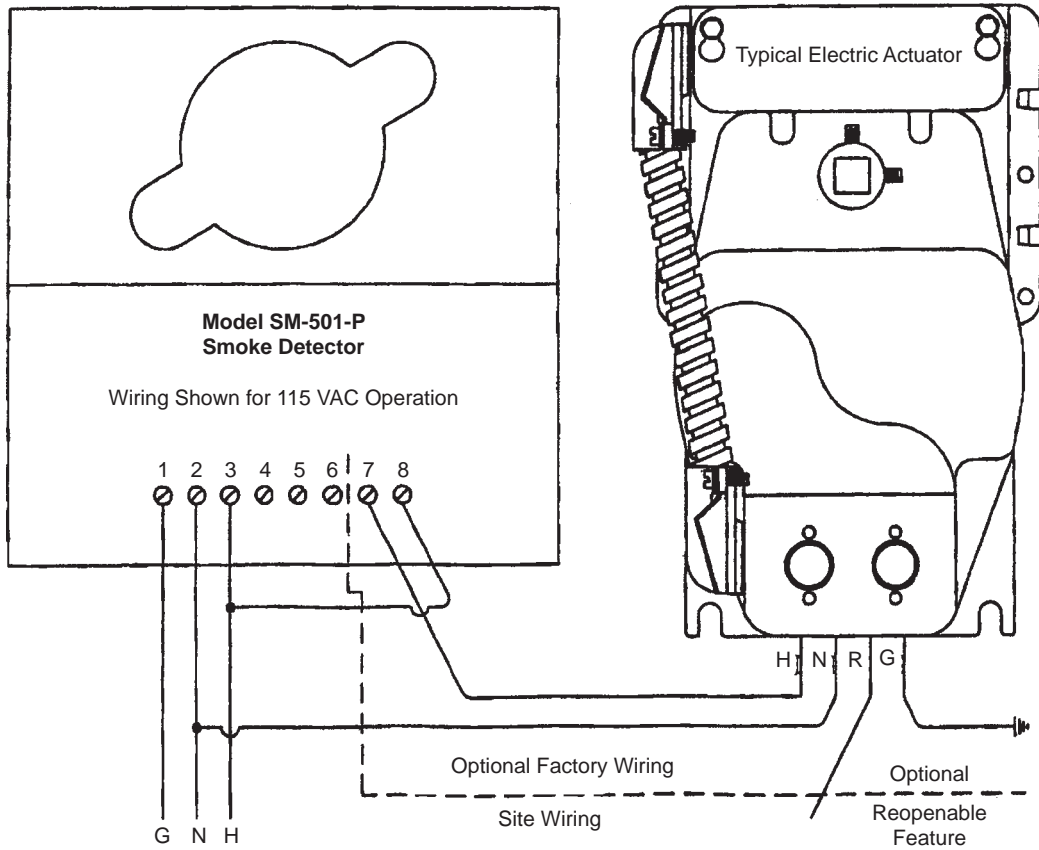

Model 2151

