

MODEL A220

4" Deep • Fixed Drainable Blade • Hurricane Louver

STANDARD MATERIALS AND CONSTRUCTION

- HEAD:** .125" thick; extruded 6063-T5 aluminum
- SILL:** .125" thick; extruded 6063-T5 aluminum
- JAMBS:** .125" thick; extruded 6063-T5 aluminum
- BLADES:** .125" thick; extruded 6063-T5 aluminum
- ASSEMBLY:** Welded and mechanical fastened
- FINISH:** Mill
- SCREEN:** 1/2" removable expanded aluminum bird screen located on interior side
- MULLIONS:** Visible with 1" wide x .08" thick 6063-T5 extruded aluminum cover (multiple panels only)

DESIGN DATA: NOA No: 08-1030.04 - TAS 201, 202, 203

This system has not been tested for water infiltration resistance and is not a water resistant system. This louver system has been designed in accordance with and meet the requirements of the FBC including High Velocity Hurricane Zones (HVHZ).

OPTIONS

- Finishes - Baked Enamel, Kynar, Anodized
- Variety of bird and insect screens
- Extended sill made from formed .063" aluminum
- Flange Frame 1 1/2"W x 1/8" thick
- Architectural Vertical Mullions
- Sill Pan

NOTES

1. "A" width and "B" height are opening dimensions. Louver frames are provided approximately 1/2" undersized.
2. Panels over 30" wide will have a 2" x 2" x 1/4" 6063-T5 aluminum support angle mounted vertically on interior at approximate midpoint.
3. Mullied panels may be horizontally installed to an unlimited number. Vertical stacking of mullied panels may occur providing a structural support is designed an installed by others to support all loads transferred from the louver assembly (single panels may run to unlimited height per elevation if no mullion exists).
4. Approved opening types: wood, steel, or concrete/masonry (masonry acceptable at jambs only, head and sill must be concrete).
5. Units are supplied with mounting angles, structural steel, and mounting hardware for concrete installation as a standard. Please specify if louvers are to be mounted in substrate other than concrete.
6. See installation sketches for required mounting structure.

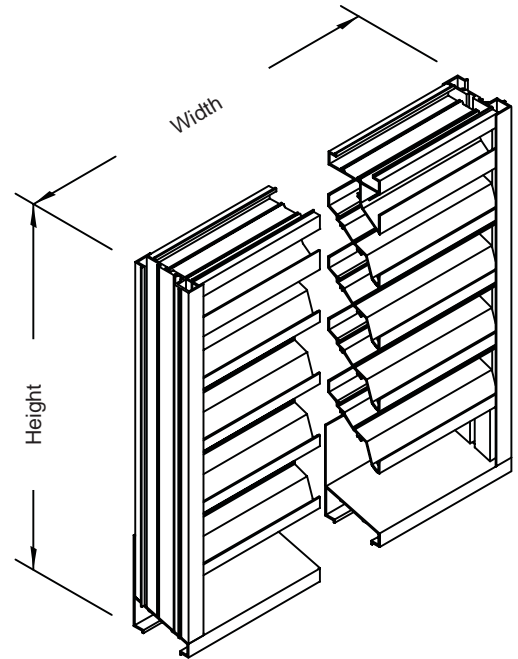

LOUVER SIZES

Panels	Minimum Panel	Maximum Single Panel
A220	12"W x 12"H	60"W x 96"H

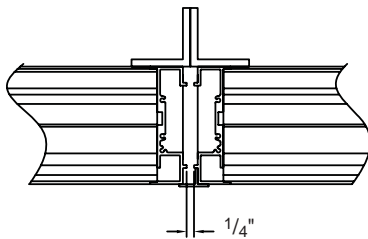

Standard Exposed Vertical Mullion

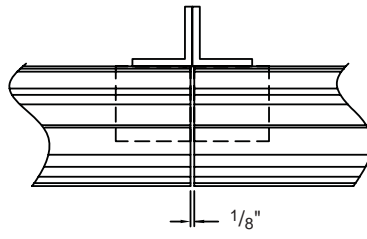

Optional Architectural Vertical Mullion

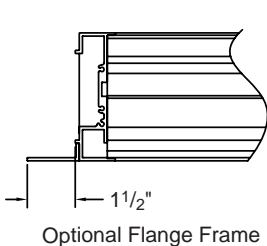

Optional Flange Frame

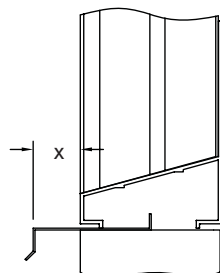

Optional Extended Sill Pan

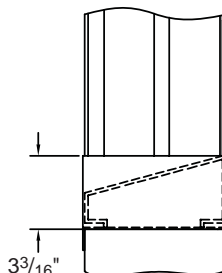

Optional Sill Pan



Air Balance Inc. certifies that the model A220 louver shown herein is licensed to bear the AMCA Seal. The ratings shown are based on tests and procedures performed in accordance with AMCA Publication 511 and comply with the requirements of AMCA Certified Ratings Program. The AMCA Certified Ratings Seal applies to Water Penetration and Air Performance Ratings only.



MODEL A220

4" Deep • Fixed Drainable Blade • Hurricane Louver

Water Penetration: 0.01 oz. (3.0 g) at 1075 fpm (5.46 m/s) maximum recommended free area velocity

Air Performance: 0.14 in.wg (34.87 Pa) at 1075 fpm (5.46 m/s) and 8232 SCFM (3.8 scm/s)

Free Area: 8.37 sq.ft. (0.778) = 52% for 48"W x 48"H (1.22m x 1.22m) test size

1. Test size is 48"W x 48"H (1.2m x 1.2m)
2. Ratings do not include the effect of a screen
3. Data is at standard air density

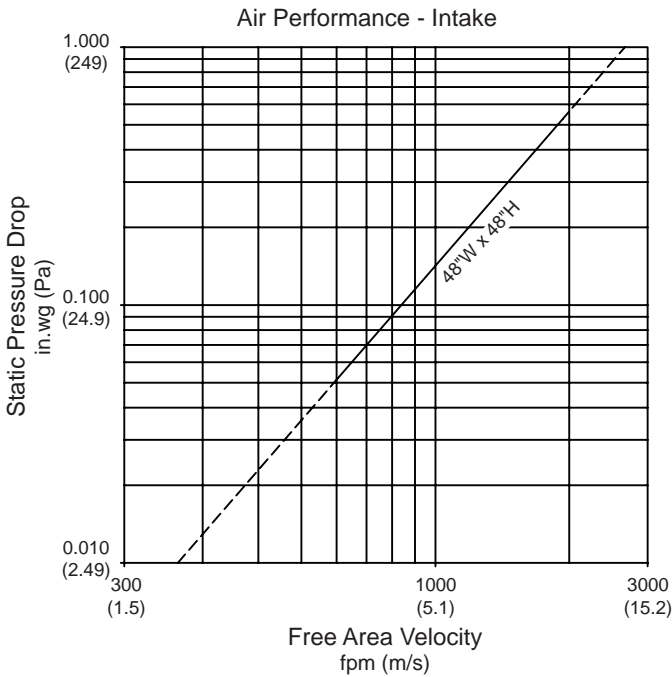

Free Area in sq.ft (sq.m)

Height	Width				
	12 (305)	24 (610)	36 (914)	48 (1219)	60 (1524)
12 (305)	0.31 (0.029)	0.70 (0.065)	1.09 (0.101)	1.48 (0.137)	1.87 (0.174)
24 (610)	0.81 (0.075)	1.82 (0.169)	2.84 (0.264)	3.86 (0.359)	4.87 (0.452)
36 (914)	1.3 (0.121)	2.94 (0.273)	4.59 (0.426)	6.23 (0.579)	7.87 (0.731)
48 (1219)	1.8 (0.167)	4.07 (0.378)	6.34 (0.589)	8.37 (0.778)	10.87 (1.01)
60 (1524)	2.29 (0.213)	5.19 (0.482)	8.08 (0.751)	10.98 (1.020)	13.88 (1.289)
72 (1829)	2.79 (0.259)	6.31 (0.586)	9.83 (0.913)	13.35 (1.240)	16.55 (1.538)
84 (2134)	3.28 (0.305)	7.43 (0.690)	11.58 (1.076)	15.73 (1.461)	19.88 (1.847)
96 (2438)	3.78 (0.351)	8.55 (0.794)	13.33 (1.238)	18.10 (1.682)	22.88 (2.126)

- To determine minimum free area required for louvers:
1. Divide the required flow by the maximum recommended free area velocity.
 2. Select the most desirable louver size from the free area table that meets the minimum free area that is required.
 3. Compare specified performance to the certified water penetration and air performance ratings.

Example:
Given 15,000 CFM design flow

1. minimum free area = $\frac{\text{design flow}}{\text{maximum recommended velocity}}$

minimum free area = $\frac{15,000}{1075} = 13.9$ sq. ft.

2. From the free area table the required louver size is 60"W x 60"H

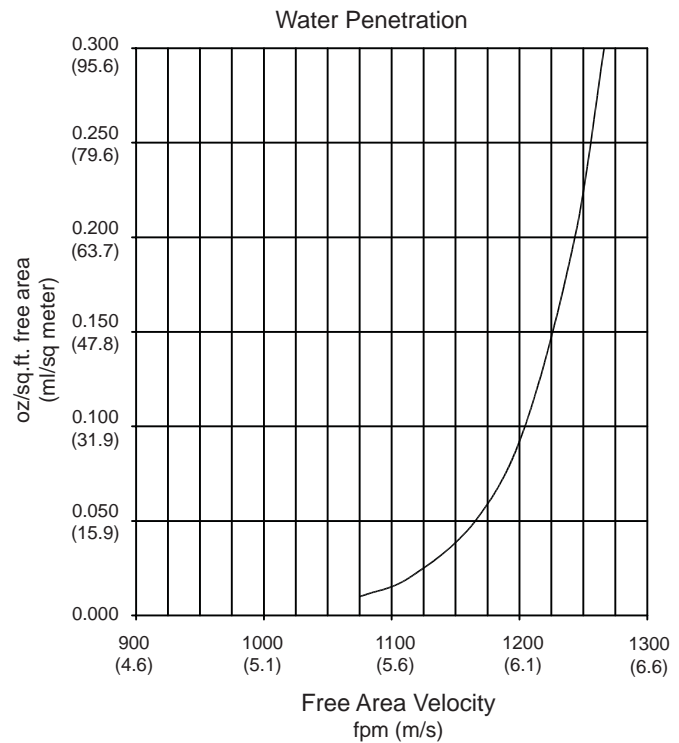

Both maximum recommended free area velocity and beginning of water penetration are 1075 fpm at standard air (.075 lbs/cu/ft). The above water penetration data is based on mill finish, 48"W x 48"H test size per AMCA Standard 511. (15 minute duration)



Air Balance Inc. certifies that the model A220 louver shown herein is licensed to bear the AMCA Seal. The ratings shown are based on tests and procedures performed in accordance with AMCA Publication 511 and comply with the requirements of AMCA Certified Ratings Program. The AMCA Certified Ratings Seal applies to Water Penetration and Air Performance Ratings only.

In the interest of product development, Air Balance reserves the right to make changes without notice.

P.O. Box 606 • 7435 Industrial Rd. • Florence, KY 41042 • Phone: (859) 538-3400 • Fax: (859) 647-7810

