

# MODEL A635A

6" Deep • Drainable Blade • Adjustable Extruded Aluminum Louver

## STANDARD MATERIALS AND CONSTRUCTION

- FRAME:** .080" thick nominal; 6063-T6/T52 extruded aluminum alloy
- BLADES:** .080" thick nominal ; 6063-T6/T52 extruded aluminum alloy
- FACE OF LOUVER:** Full width sill with drain head and drain blades contained within the drain jambs.
- LINKAGE:** Extruded aluminum, concealed in channel out of airstream. Pivots are .50 dia. machined steel. Cadmium plated and chromate treated. Pivots rotate in a celcon bearing. A .312" dia. Aluminum linkage rod is locked to the pivot by a 1/4 - 20 set screw with epoxy locking patch.
- SHAFT:** .50 dia. aluminum "Pin-Lock" Rod.
- BLADE SEALS:** Extruded silicone rubber seal at blade edge.
- JAMB SEALS:** Polyurethane
- SCREEN:** 1/2" x .051" flattened aluminum bird screen
- FINISH:** Mill

## OPTIONS

- Finish - Baked Powder Polyester , Kynar, or Anodize
- Variety of Bird and Insect Screen
- 1 1/8" Usable Flange Frame
- Blank-off Panels
- Actuators (Electric, Pneumatic, Manual, etc.)

## NOTES

1. "A" width and "B" height are opening dimensions. Louvers are provided approximately 1/2" undercut.
2. Shipping weight approximately 5.6 lbs./sq.ft.

## LOUVER SIZES

Panels	Min Panel	Max Single Panel
A635A	12"W x 12"H	48"W x 96"H

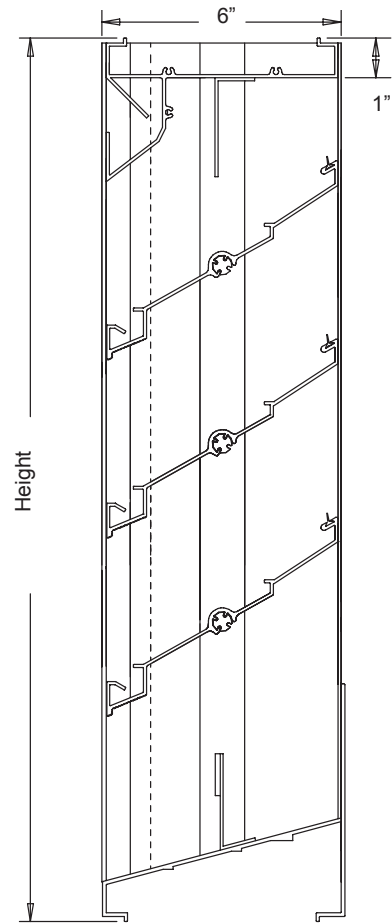

Section View

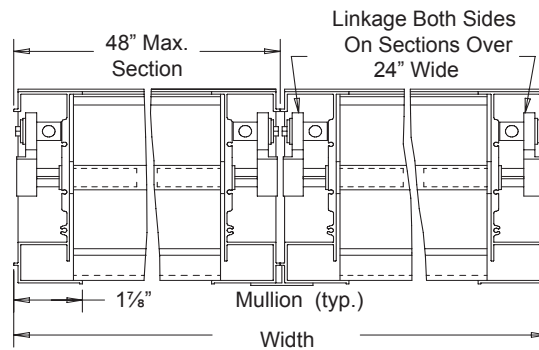
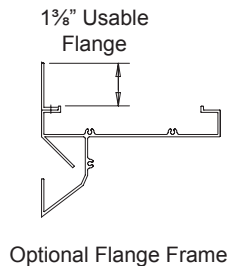

air balance

Dampers  Louvers  
 UL Life Safety Products  
 Division of Mestek  
 Member of AMCA

# MODEL A635A

6" Deep • Drainable Blade • Adjustable Extruded Aluminum Louver

Water Penetration: 800 fpm recommended maximum free area velocity  
 Pressure Drop: 0.145 in.wg at 1000 fpm and 7550 scfm  
 Free Area: 8.58 sq.ft. = 54% for 48"W x 48"H test size

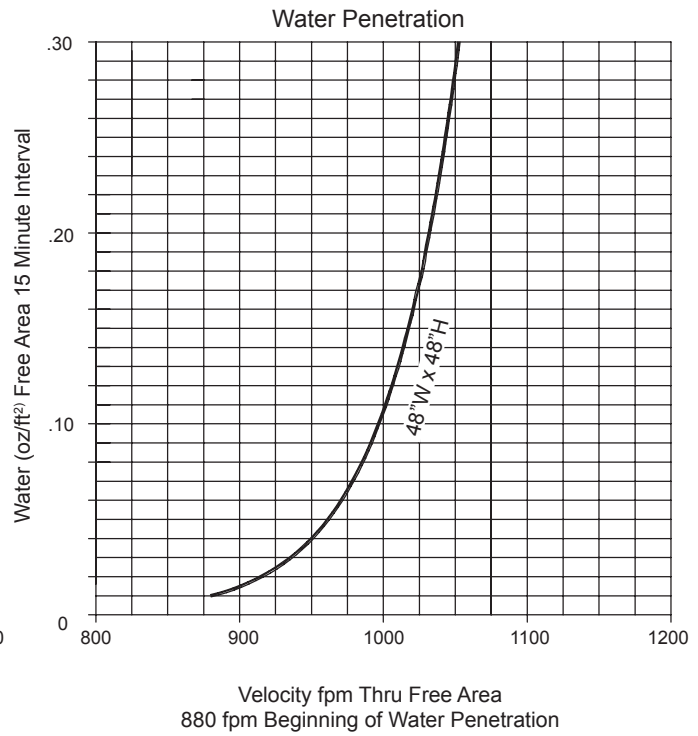
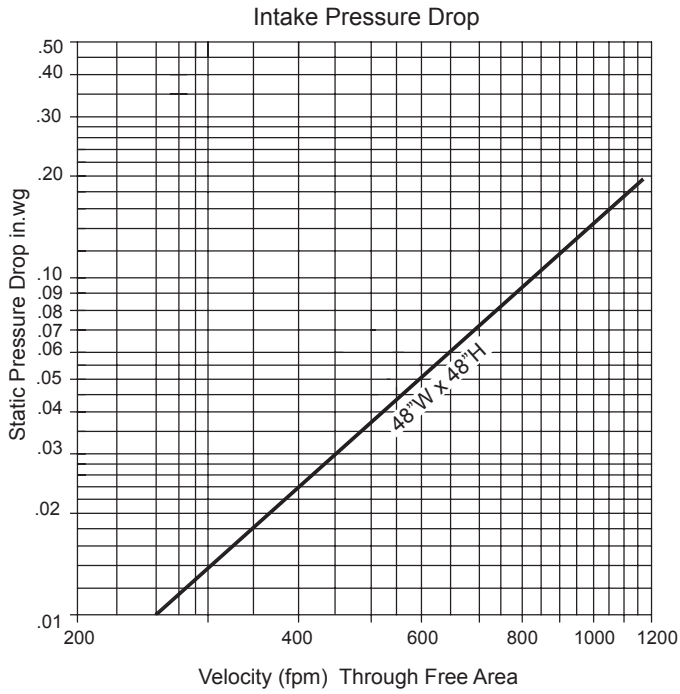

Free Area sq.ft

		Width						
		12"	18"	24"	30"	36"	42"	48"
Height	12"	0.21	0.36	0.51	0.67	0.82	0.98	1.13
	24"	0.53	0.93	1.33	1.73	2.13	2.53	2.93
	36"	1.02	1.79	2.56	3.32	4.09	4.86	5.62
	48"	1.51	2.65	3.78	4.92	6.05	7.19	8.58
	60"	1.84	3.22	4.60	5.98	7.36	8.74	10.12
	72"	2.33	4.08	5.82	7.57	9.32	11.07	12.81
	84"	2.82	4.93	7.05	9.16	11.28	13.39	15.51
	96"	3.15	5.51	7.87	10.23	12.59	14.95	17.31

air balance

Dampers  Louvers  
 UL Life Safety Products  
 Division of Mestek  
 Member of AMCA