

# MODEL A665C

6" Deep • Drainable • Combination Adjustable And Stationary Extruded Aluminum Louver

## STANDARD MATERIALS AND CONSTRUCTION

**FRAME:** .080" thick nominal; 6063-T6/T52 extruded aluminum alloy

**BLADES:** Stationary blade .080" thick nominal ; 6063-T6/T52 extruded aluminum alloy.  
Adjustable blade .125" thick nominal; 6063-T6/T52 extruded aluminum alloy.

**FACE OF LOUVER:** Full width sill with head and blades contained within the jambs.

**LINKAGE:** Extruded aluminum, concealed in channel out of airstream. Pivots are .50 dia. machined steel. Cadmium plated and chromate treated. Pivots rotate in a celcon bearing. A .312" dia. Aluminum linkage rod is locked to the pivot by a 1/4 - 20 set screw with epoxy locking patch.

**SHAFT:** .50 dia. aluminum "Pin-Lock" Rod.

**BLADE SEALS:** Extruded silicone rubber seal at blade edge.

**JAMB SEALS:** Stainless steel jamb seals.

**SCREEN:** 1/2" x .051" flattened aluminum bird screen

**FINISH:** Mill

## OPTIONS

Finish - Baked Powder Polyester , Kynar, or Anodize

Variety of Bird and Insect Screen

1 3/8" Usable Flange Frame

Blank-off Panels

Actuators (Electric, Pneumatic, Manual, etc.)

## NOTES

- "A" width and "B" height are opening dimensions. Louvers are provided approximately 1/2" undercut.
- Shipping weight approximately 5.7 lbs./sq.ft.

## LOUVER SIZES

Panels	Min Panel	Max Single Panel
A665C	12"W x 12	48"W x 96"H

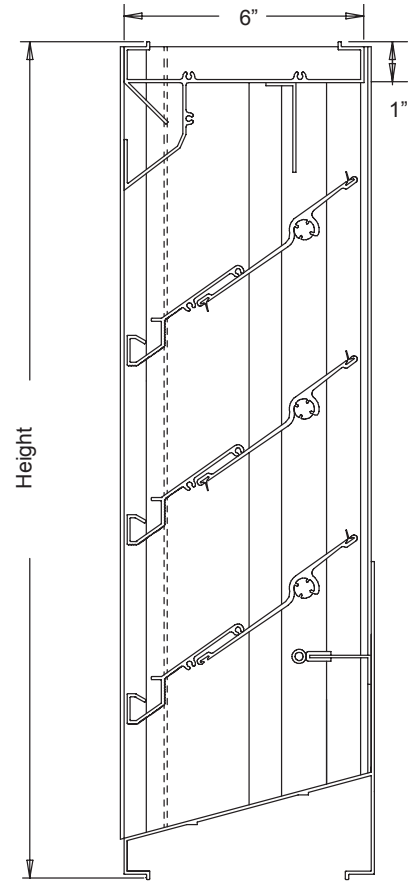

Section View

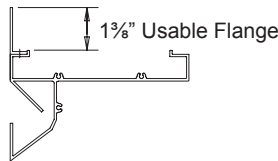

Optional Flange Frame

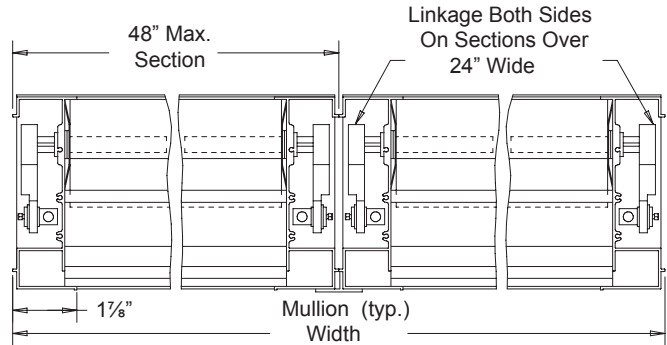

air balance

Dampers  Louvers  
UL Life Safety Products  
Division of Mestek  
Member of AMCA

# MODEL A665C

6" Deep • Drainable • Combination Adjustable And Stationary Extruded Aluminum Louver

Water Penetration: 1000 fpm recommended maximum free area velocity  
 Pressure Drop: 0.12 in.wg at 1050 fpm and 8652 scfm  
 Free Area: 8.24 sq.ft. = 52% for 48"W x 48"H test size

Ratings do not include effects of birdscreen

Intake Pressure Drop

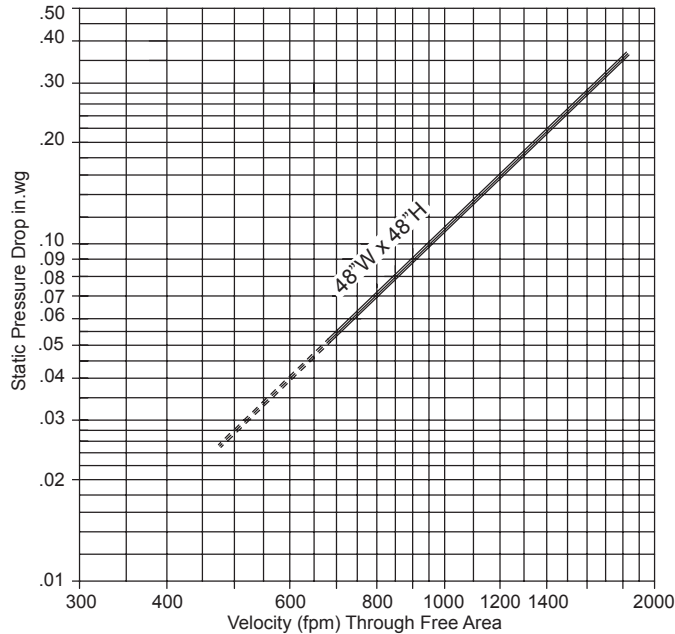

Water Penetration

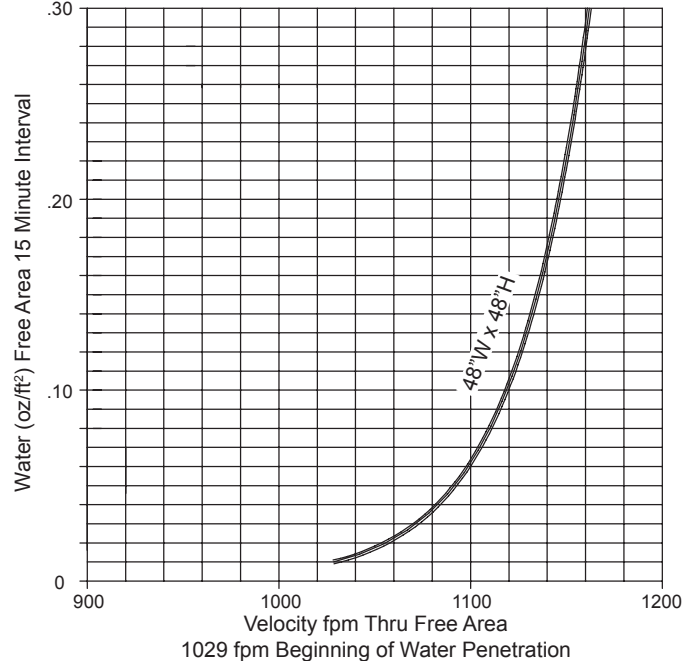

Free Area sq.ft.

Height	Width						
	12"	18"	24"	30"	36"	42"	48"
12"	0.14	0.24	0.34	0.45	0.55	0.65	0.76
24"	0.64	1.12	1.60	2.08	2.55	3.05	3.51
36"	1.00	1.76	2.51	3.26	4.02	4.77	5.52
48"	1.50	2.62	3.74	4.87	5.99	7.11	8.24
60"	2.00	3.50	4.99	6.49	7.99	9.49	10.99
72"	2.36	4.14	5.91	7.68	9.45	11.23	13.00
84"	2.86	5.00	7.14	9.28	11.42	13.57	15.71
96"	3.36	5.87	8.39	10.91	13.43	15.94	18.46

Air Leakage with adjustable blade in closed position with a seating torque of 6.25 in.lb. / sq.ft. of louver face area. Leakage is based on a test of a 48" x 48" louver.

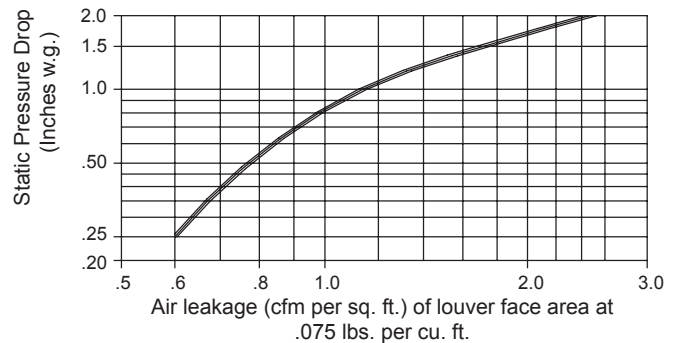

Air leakage (louver installation position, intake) is per AMCA Standard 500 Procedure Fig. 5.5.



Air Balance certifies that the Model A668C Louver shown herein is licensed to bear the AMCA seal. The rating shown are based on test and procedures performed in accordance with AMCA Publication 511 and comply with the requirements of the AMCA Certified rating program. The AMCA Certified Ratings Seal applies to Air Performance Ratings and Water Penetration Ratings.

