

MODEL A680

6" Deep • Fixed Chevron Blade • Hurricane Louver

STANDARD MATERIALS AND CONSTRUCTION

- HEAD:** .125" thick; extruded 6063-T6 aluminum
- SILL:** .125" thick; extruded 6063-T6 aluminum
- JAMBS:** .080" thick; extruded 6063-T6 aluminum
- BLADES:** .081" thick; extruded 6063-T6 aluminum
- SILL PAN:** .060" thick; formed aluminum

BLADE SPACING: 1.625"

ASSEMBLY: Mechanical fastened

FINISH: Mill

SCREEN: 1/2" removable expanded aluminum bird screen located on interior

MULLIONS: Exposed, vertical with 1.75" x .08" 6063-T5 extruded aluminum cover (multiple panels only)

DESIGN DATA: NOA Pending - TAS 100 with damper in sleeve, TAS 201, 202, 203
ASTM E1996 "E", ASTM E330, ASTM E1886

This system has been tested for water infiltration resistance and is a water resistant system when an AFD20 or AC525/526 damper is installed with the louver panel. This louver system has been designed in accordance with and meet the requirements of the FBC including High Velocity Hurricane Zones (HVHZ).

OPTIONS

- Finishes - Baked Enamel, Kynar, Anodize
- Variety of bird and insect screens
- Extended Sill (Formed .063" aluminum)
- Flange Frame 1 1/2"W x 1/8" thick
- Architectural Vertical Mullion
- Sleeve
- Sleeve with Damper

NOTES

1. "A" width and "B" height are opening dimensions. Louvers are provided approximately 1" undersize.
2. Louver panels may be butted together to infinite width with a maximum height of 96". Maximum single panel is 48"W x 96"H.
3. Approved opening types: wood, steel, or concrete/masonry (masonry acceptable at jambs only, head and sill must be concrete). Anchoring details may vary.
4. Units are supplied with 2" x 2" mounting angles and mounting hardware for concrete installation as a standard. Please specify if louvers are to be mounted in substrate other than concrete, OR if the installation will require a 2" x 4" mounting angle. Larger, 2" x 4" mounting angles may be required to either maintain the minimum edge distance, or to ensure that the screws don't penetrate the sill pan of the louver.
5. See installation sketches for required mounting structure.

LOUVER SIZES

Panels	Min Panel	Max Single Panel
A680	12"W x 12"H	48"W x 96"H

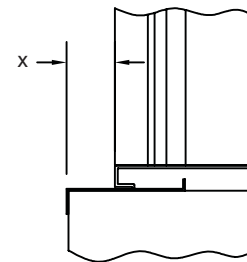
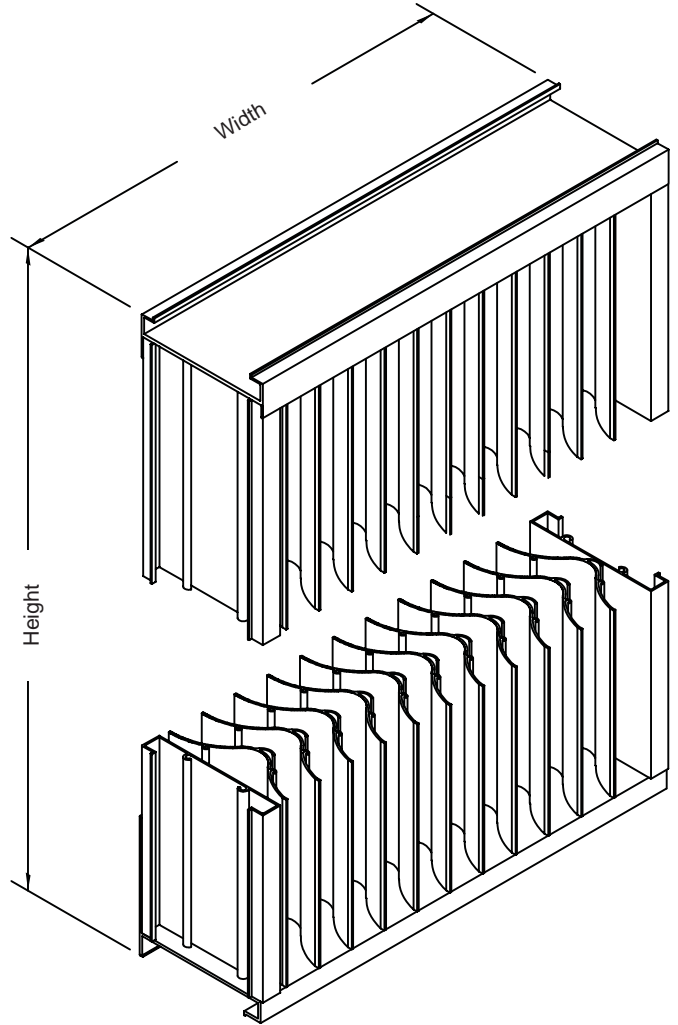

Optional Extended Sill

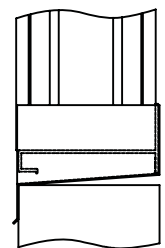

Standard Sill Pan

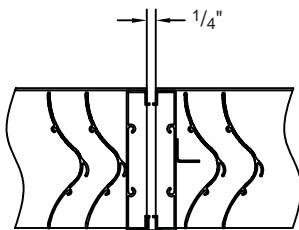

Standard Exposed Vertical Mullion

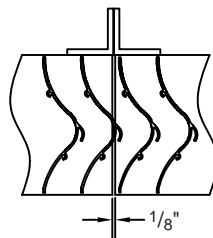

Optional Architectural Vertical Mullion

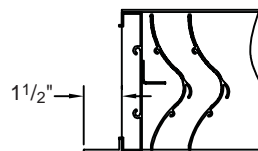

Optional Flange Frame

Air Balance Inc. certifies that the model A680 louver shown herein is licensed to bear the AMCA Seal. The ratings shown are based on tests and procedures performed in accordance with AMCA Publication 511 and comply with the requirements of AMCA Certified Ratings Program. The AMCA Certified Ratings Seal applies to Water Penetration and Air Performance Ratings only.



MODEL A680

6" Deep • Fixed Chevron Blade • Hurricane Louver

- Air Performance:** 0.164 in.wg (40.6 Pa) at 1250 fpm (6.35 m/s) and 9813 scfm (4.63 scm/s)
Free Area: 7.85 sq.ft. (0.729 sq.m) = 49.1% for 48"W x 48"H (1.22m x 1.22m) test size
1. Test size is 48"W x 48"H (1.2m x 1.2m)
 2. Ratings do not include the effect of a screen.
 3. Data is at standard air density (0.75 lbs/cu ft.).

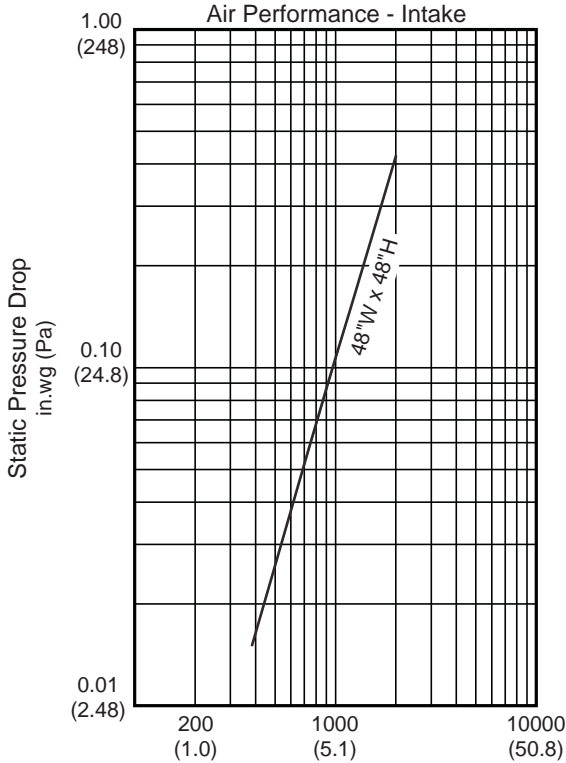

Free Area in sq.ft. (sq m)

Height	Width							
	12 (305)	24 (610)	36 (914)	48 (1219)	60 (1524)	72 (1829)	84 (2134)	96 (2438)
12 (305)	0.28 (0.026)	0.67 (0.062)	1.09 (0.101)	1.52 (0.141)	1.90 (0.177)	2.33 (0.216)	2.71 (0.252)	3.14 (0.292)
24 (610)	0.67 (0.062)	1.59 (0.148)	2.61 (0.242)	3.63 (0.337)	4.55 (0.423)	5.56 (0.517)	6.48 (0.602)	7.50 (0.697)
36 (914)	1.07 (0.099)	2.52 (0.234)	4.13 (0.384)	5.74 (0.533)	7.19 (0.668)	8.80 (0.818)	10.25 (0.952)	11.86 (1.102)
48 (1219)	1.46 (0.136)	3.44 (0.320)	5.65 (0.525)	7.85 (0.729)	9.83 (0.913)	12.04 (1.119)	14.02 (1.303)	16.22 (1.507)
60 (1524)	1.85 (0.172)	4.37 (0.406)	7.16 (0.665)	9.96 (0.925)	12.48 (1.159)	15.27 (1.419)	17.79 (1.653)	20.59 (1.913)
72 (1829)	2.24 (0.208)	5.30 (0.492)	8.68 (0.806)	12.07 (1.121)	15.12 (1.405)	18.51 (1.720)	21.56 (2.003)	24.95 (2.318)
84 (2134)	2.63 (0.244)	6.22 (0.578)	10.20 (0.946)	14.18 (1.317)	17.77 (1.651)	21.75 (2.021)	25.33 (2.353)	29.31 (2.723)
96 (2438)	3.03 (0.281)	7.15 (0.664)	11.72 (1.089)	16.29 (1.513)	20.41 (1.896)	24.98 (2.321)	29.11 (2.704)	33.68 (3.129)

Standard air - 0.075 lbs. per cu.ft.
 Ratings do not include the effect of a wire birdscreen.
 Test based on a 48"W x 48"H test size per AMCA Standard 511.

Blade Spacing	Rainfall Rate	Wind Velocity	Core Velocity	Airflow	Free Area Velocity	Water Penetration Effectiveness	Discharge Loss Coefficient
2" (50.8 mm)	3 in/hr (76 mm/h)	29 mph (46.7 kph)	980 fpm (5 m/s)	10546 cfm (299 m³/min)	2170 fpm (11 m/s)	100% - Class A	≥ 0.4 - Class 1
2" (50.8 mm)	8 in/hr (203 mm/h)	50 mph (80.47 kph)	784 fpm (4 m/s)	8440 cfm (239 m³/min)	1736 fpm (8.8 m/s)	99.2% - Class A	≥ 0.4 - Class 1
2" (50.8 mm)	8 in/hr (203 mm/h)	50 mph (80.47 kph)	877 fpm (4.5 m/s)	9445 cfm (267 m³/min)	1943 fpm (9.9 m/s)	99.1% - Class A	≥ 0.4 - Class 1
2" (50.8 mm)	8 in/hr (203 mm/h)	50 mph (80.47 kph)	982 fpm (5 m/s)	10578 cfm (300 m³/min)	2176 fpm (11 m/s)	99.1% - Class A	≥ 0.4 - Class 1

Wind Driven Rain Performance Test based on 39.37"W x 39.37"H (1m x 1m) Core Area Louver with 5.88 ft² (0.546m²) Free Area.

Air Balance Inc. certifies that the model A680 louver shown herein is licensed to bear the AMCA Seal. The ratings shown are based on tests and procedures performed in accordance with AMCA Publication 511 and comply with the requirements of AMCA Certified Ratings Program. The AMCA Certified Ratings Seal applies to Water Penetration and Air Performance Ratings only.

