

MODEL A820

8" Deep • Fixed Chevron Blade • Hurricane Louver

STANDARD MATERIALS AND CONSTRUCTION

- HEAD:** .125" thick; formed 6063-T5 aluminum
- SILL:** .125" thick; formed 6063-T5 aluminum
- JAMBS:** .125" thick; extruded 6063-T5 aluminum
- BLADES:** .24" thick at edges, reducing to .063" thickness at mid point of profile
- SILL PAN:** Integral to louver
- BLADE SPACING:** 1.25"
- ASSEMBLY:** Welded
- FINISH:** Mill
- SCREEN:** None
- MULLIONS:** Exposed, vertical with 1.75" x .08" 6063-T5 extruded aluminum cover (multiple panels only)
- DESIGN DATA:** NOA 08-1202.06
TAS 100
TAS 201, 202, 203
ASTM E1996, ASTM E330, ASTM E1886

This system has been tested for water infiltration resistance and is a water resistant system. This louver system has been designed in accordance with and meet the requirements of the FBC including High Velocity Hurricane Zones (HVHZ).

OPTIONS

- Finishes - Baked Enamel, Kynar, Anodize
- Variety of bird and insect screens
- Extended Sill (Formed .063" aluminum)
- Sleeve

NOTES

1. "A" width and "B" height are opening dimensions. Louvers are provided approximately 1/2" undersize.
2. Louver panels may be butted together to infinite width with a maximum height of 96". Maximum single panel is 48"W x 96"H.
3. Approved opening types: wood, steel, or concrete/masonry (masonry acceptable at jambs only, head and sill must be concrete). Anchoring details may vary.
4. Units are supplied with 2" x 2" mounting angles and mounting hardware for concrete installation as a standard. Please specify if louvers are to be mounted in substrate other than concrete, OR if the installation will require a 2" x 4" mounting angle. Larger, 2" x 4" mounting angles may be required to either maintain the minimum edge distance, or to ensure that the screws don't penetrate the sill pan of the louver.
5. See installation sketches for required mounting structure.

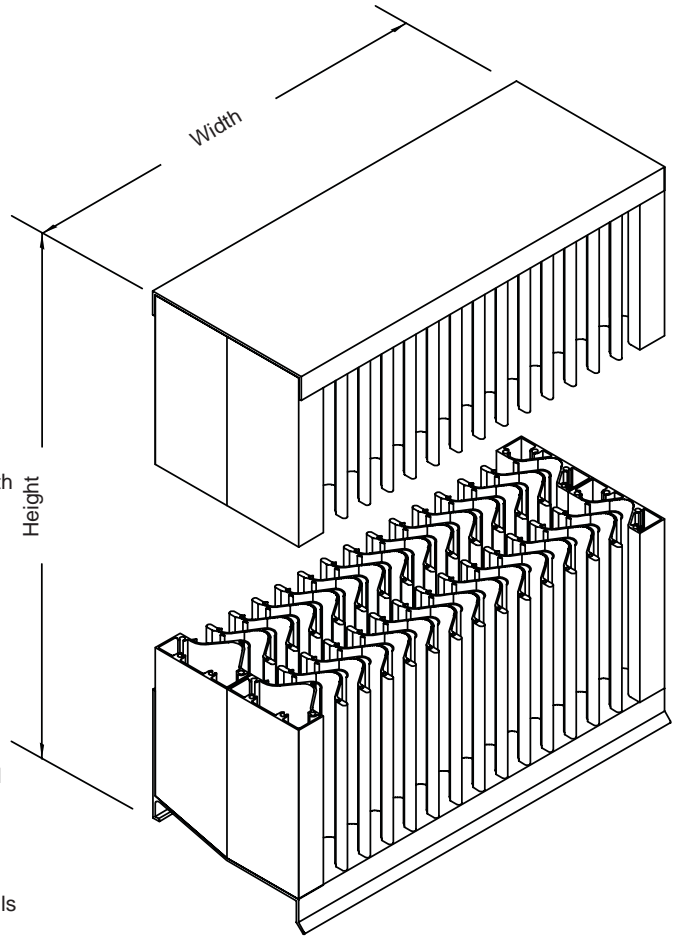

LOUVER SIZES

Panels	Min Panel	Max Single Panel
A820	12"W x 12"H	48"W x 96"H

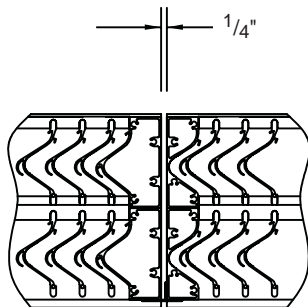

Standard Exposed Vertical Mullion

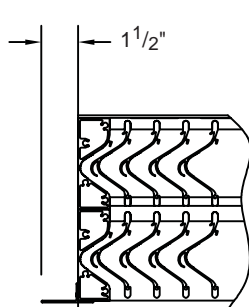

Optional Flange Frame

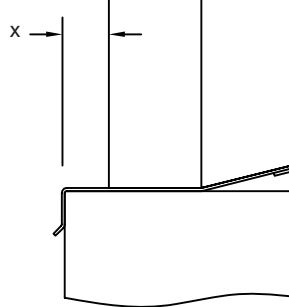

Optional Extended Sill



Air Balance Inc. certifies that the model A820 louver shown herein is licensed to bear the AMCA Seal. The ratings shown are based on tests and procedures performed in accordance with AMCA Publication 511 and comply with the requirements of AMCA Certified Ratings Program. The AMCA Certified Ratings Seal applies to Water Penetration and Air Performance Ratings only.



MODEL A820

8" Deep • Fixed Chevron Blade • Hurricane Louver

Air Performance: 0.30 in.wg (74.73 Pa) at 1250 fpm (6.4 m/s) and 5862.5 scfm (2.8 scm/s)

Free Area: 4.69 sq ft (0.435 sq m) = 29.31%

1. Test size is 48"W x 48"H (1.2m x 1.2m).
2. Ratings do not include the effect of a screen.
3. Data is at standard air density.

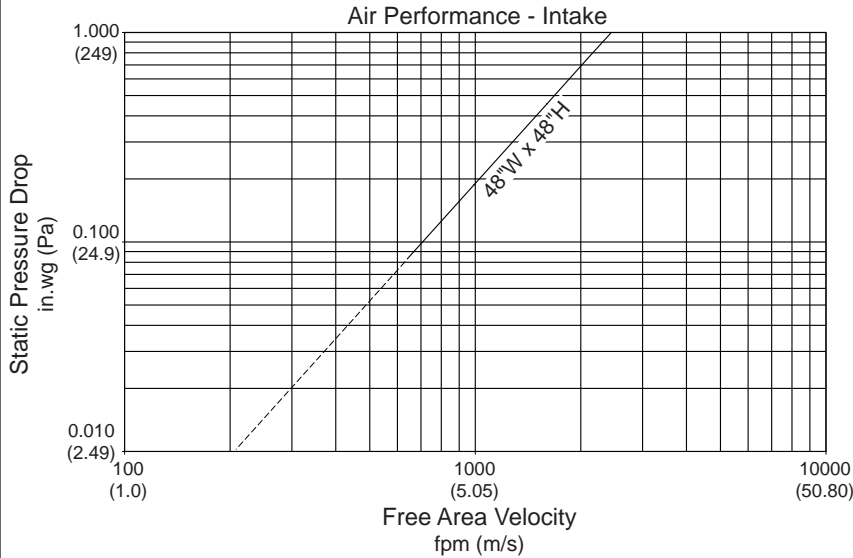

Free Area in sq.ft.(sq.m)

		Width			
		12 (305)	24 (610)	36 (914)	48 (1219)
Height	12 (305)	0.10 (0.009)	0.22 (0.021)	0.36 (0.033)	0.49 (0.045)
	24 (610)	0.38 (0.036)	0.88 (0.082)	1.40 (0.130)	1.90 (0.177)
	36 (914)	0.67 (0.062)	1.53 (0.142)	2.45 (0.227)	3.31 (0.308)
	48 (1219)	0.95 (0.088)	2.19 (0.203)	3.49 (0.324)	4.69 (0.435)
	60 (1524)	1.24 (0.115)	2.84 (0.264)	4.54 (0.421)	6.14 (0.571)
	72 (1829)	1.52 (0.141)	3.50 (0.325)	5.58 (0.518)	7.56 (0.702)
	84 (2134)	1.80 (0.168)	4.15 (0.386)	6.62 (0.615)	8.97 (0.833)
	96 (2438)	2.09 (0.194)	4.80 (0.446)	7.67 (0.712)	10.38 (0.965)

To determine minimum free area required for louvers:

1. Divide the required flow by the maximum recommended free area velocity.
2. Select the most desirable louver size from the free area table that meets the minimum free area that is required.
3. Compare specified performance to the certified water penetration and air performance ratings.

Example:

Given 10,000 CFM design flow

$$\text{minimum free area} = \frac{\text{design flow}}{\text{maximum recommended velocity}}$$

$$\text{minimum free area} = \frac{10,000}{1000} = 10 \text{ sq.ft.}$$

2. From the free area table the required louver size 48"W x 96"H.

Blade Spacing	Rainfall Rate	Wind Velocity	Core Velocity	Airflow	Free Area Velocity	Water Penetration Effectiveness	Discharge Loss Coefficient
1.25" (31.75mm)	8 in/hr (203 mm/hr)	50 mph (80.47 kph)	970 fpm (4.9 m/s)	10447cfm (296 m ³ /min)	2208 fpm (11.2 m/s)	100% - Class I	≤ .199 - Class 4

Wind Driven Rain Performance Test based on 39.37"W x 39.37"H (1m x 1m) Core Area Louver with 3.43 ft² (.319m²) Free Area.



Air Balance Inc. certifies that the model A820 louver shown herein is licensed to bear the AMCA Seal. The ratings shown are based on tests and procedures performed in accordance with AMCA Publication 511 and comply with the requirements of AMCA Certified Ratings Program. The AMCA Certified Ratings Seal applies to Water Penetration and Air Performance Ratings only.



In the interest of product development, Air Balance reserves the right to make changes without notice.

P.O. Box 606 • 7435 Industrial Rd. • Florence, KY 41042 • Phone: (859) 538-3400 • Fax: (859) 647-7810