

# MODEL BID4

4" Deep • "Tear Drop" Design Blade • 180°F Max. Temperature • Formed Steel Backdraft Damper

## STANDARD MATERIALS AND CONSTRUCTION

- FRAME:** 10-GA thick, galvanized steel
- BLADES:** 16-GA thick, galvanized steel
- BLADE SPACING:** 3<sup>3</sup>/<sub>8</sub>" minimum to 7<sup>1</sup>/<sub>8</sub>" maximum
- LINKAGE:** 1/8" thick plated steel bracket with 1/2" dia. plated steel pivot riding in a celcon sleeve bearing; Linkage rod is 5/16" dia. aluminum locked to pivot with a 1/4"-20 UNC plated steel set screw; single linkage for panels < 20"W; double linkage for panels > 20"W
- AXLES:** 3/4" dia. steel; Full length of blade
- BEARINGS:** Bronze oilite
- SEALS:** Polyurethane on blade edges, none at jamba
- FINISH:** Mill

## OPTIONS

- Frames that Completely Contain Blades and Linkage
- Flange Frame (Airflow Must be Specified)
- Jamb Seals to Provide Low Leakage
- Stainless Steel Blade Seal (0.010" thick)
- Counterweights (Assist or Resist Must be Specified)
- Variety of Bird and Insect Screens

## NOTES

1. "A" width and "B" height are opening dimensions. Dampers are provided approximately 1/2" undersize.

## DAMPER SIZES

Panels	Min Panel	Max Single Panel
BID4	12"W x 12"H	48"W x 72"H

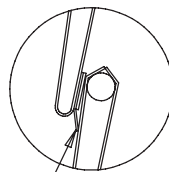
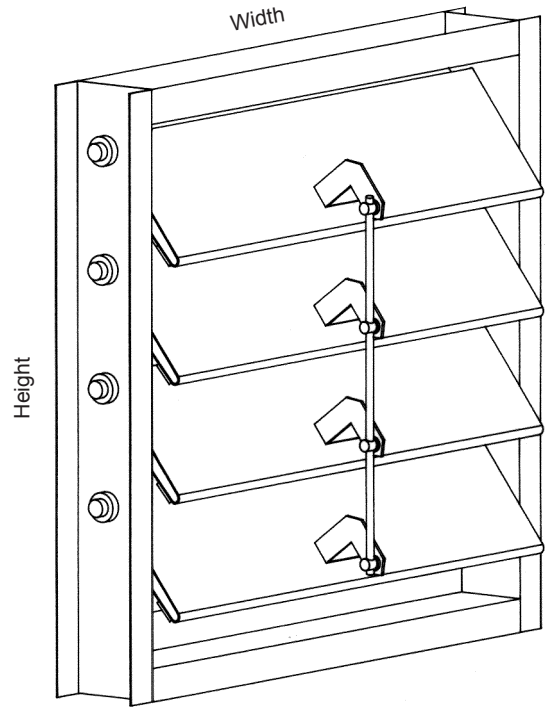

Optional Stainless Steel Blade Seal; .010" Thick

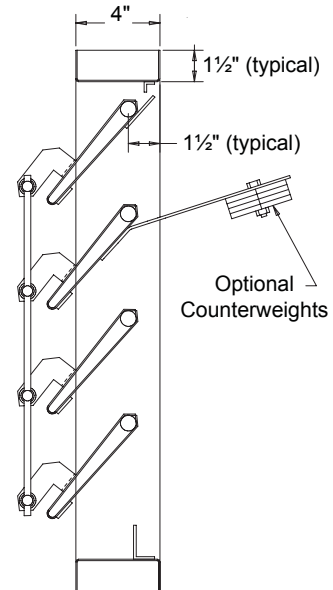

# MODEL BID4

4" Deep • "Tear Drop" Design Blade • 180°F Max. Temperature • Formed Steel Backdraft Damper

**Pressure Drop:**

Performance is based on AMCA Standard 500, Figure 5.4 (without ductwork) or Figure 5.3 (in-duct mount), operating temperatures below 180°F and a standard air density of 0.75 lb/ft<sup>3</sup>. Actual pressure drop performance will vary based on damper size and exact installation configuration. The curves shown below are furnished with counterweights to assist opening.

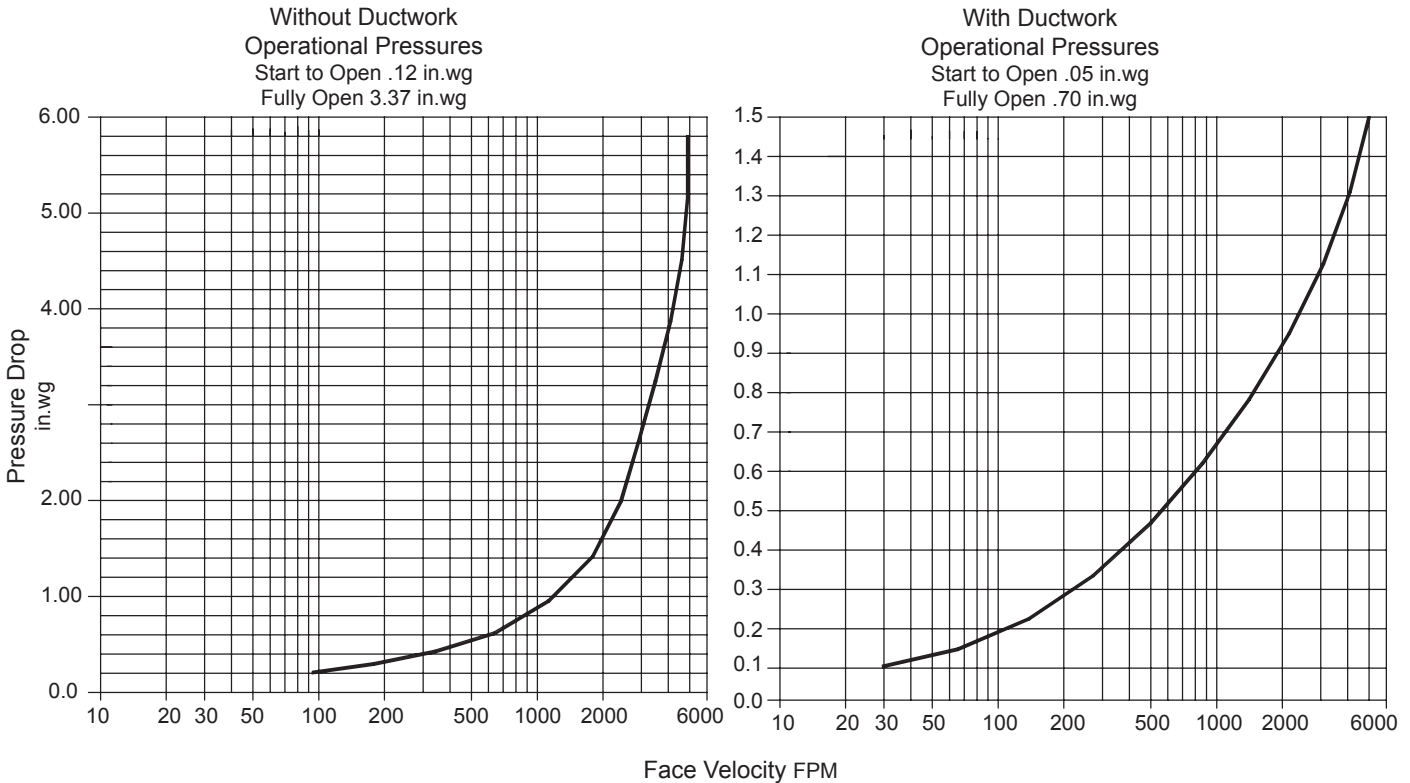

Typical performance for BID4 backdraft damper size tested 42"W x 42"H furnished with counterweight to assist opening.

**Air Leakage:**

Air leakage quantities shown in the chart are results of tests per AMCA Standard 500 and are shown at 1 in.wg differential pressure and corrected to 0.75 lb/cu.ft. air density. For determining leakage values greater than 1 in.wg to a maximum 10 in.wg use the multiplier correction chart.

Total CFM Air Leakage at 1 in.wg  
Differential Through Closed Damper

		Width						
		12	18	24	30	36	42	48
Height	12	8	12	16	20	24	28	32
	24	16	24	32	40	48	56	64
	36	24	36	48	60	72	84	96
	48	32	48	64	80	96	112	128
	60	40	60	80	100	120	140	160
	72	48	72	96	120	144	168	192

For determining leakage values greater than 1 in.wg to a maximum 10 in.wg use the multiplier correction chart below.

Static Pressure	2	3	4	5	6	7	8	9	10
Multiplier Correction Factor	1.3	1.5	1.8	2.0	2.3	2.5	2.8	3.0	3.3

Air leakage ratings are based on AMCA Standard 500 using test set up Fig. 5.4 with damper in the closed position without the aid of a counterweight or other mechanical means to provide closing torque. For a size 42"W x 42"H damper with blade and jamb seals.