

# MODEL BSL

2" Deep • Single Thickness Blade • Aluminum Construction • Light Duty Backdraft Damper

## STANDARD MATERIALS AND CONSTRUCTION

- FRAME:** .093" thick, 5/8" x 2" x 5/8" extruded aluminum channel
- BLADE:** .032" thick aluminum, formed over a 3/16" dia. steel rod
- SEALS:** Polyurethane foam at blade edges, none at jamb
- BEARINGS:** Bronze oilite
- LINKAGE:** Aluminum chevron bracket with aluminum linkage bar
- FINISH:** Mill

## OPTIONS

- Flange Frame
- No Blade to Blade Linkage
- Adjustable Counterbalance
- (Specify to Assist or Resist Opening, Linkage Must be Used)

## NOTES

1. "A" width and "B" height are opening dimensions. Dampers are provided 1/4" undercut.
2. Specify air flow as horizontal, vertical up, or vertical down.

## DAMPER SIZES

Panels	Min Panel	Max Single Panel
BSL	8"W x 8"H	48"W x 72"H

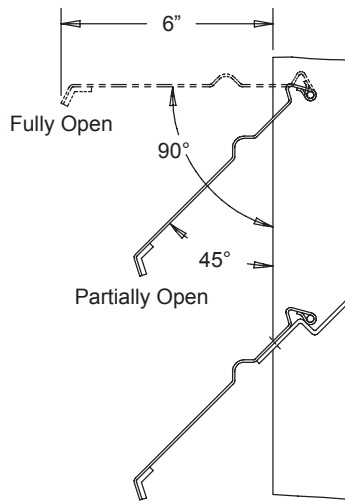

Clearance Dimensions

Optional: Adjustable Counterbalance with Variable Counterweights for Calibration. Blade Linkage Required.

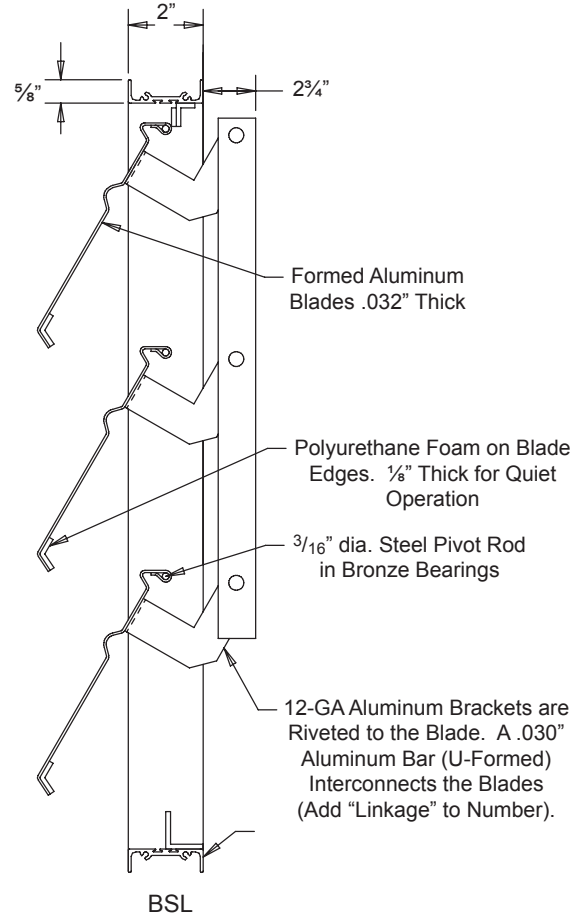

BSL

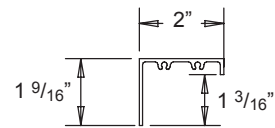

BSL2  
Flange Frame  
.080" Thick Frame

# MODEL BSL

2" Deep • Single Thickness Blade • Aluminum Construction • Light Duty Backdraft Damper

**Velocity vs. Pressure Drop:** Typical performance for model BSL backdraft damper size tested 42"W x 42"H, furnished with counterweight to assist opening.

Without Ductwork  
 Dampers installed per AMCA 500 Fig. 5.4  
 (Face Mounted to a Plenum)  
 Pressure is Corrected to .075 lb./cu.ft. Air Density  
 Operational Pressure  
 Start to Open - .01 in.wg  
 Fully Open - .35 in.wg

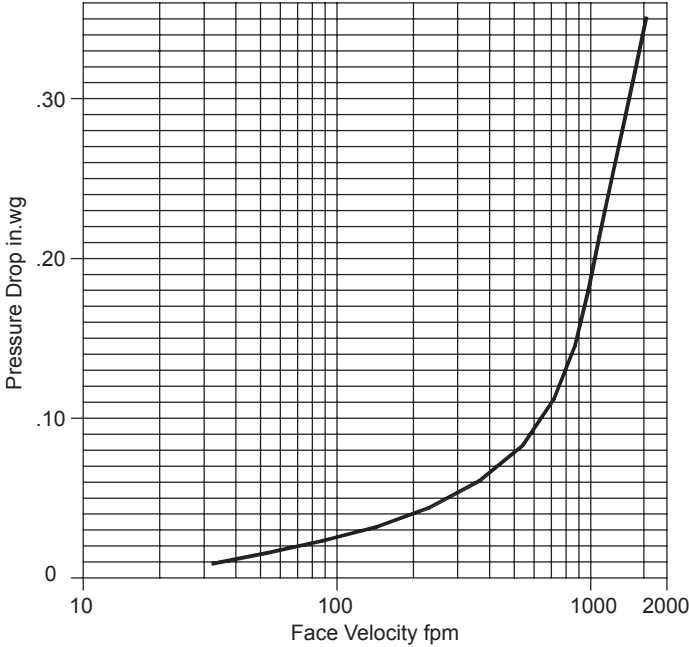

With Ductwork  
 Dampers installed per AMCA 500 Fig. 5.3  
 (Ductwork Installed Upstream and Downstream of Damper)  
 Pressure is Corrected to .075 lb./cu.ft. Air Density  
 Operational Pressure  
 Start to Open - .01 in.wg  
 Fully Open - .06 in.wg

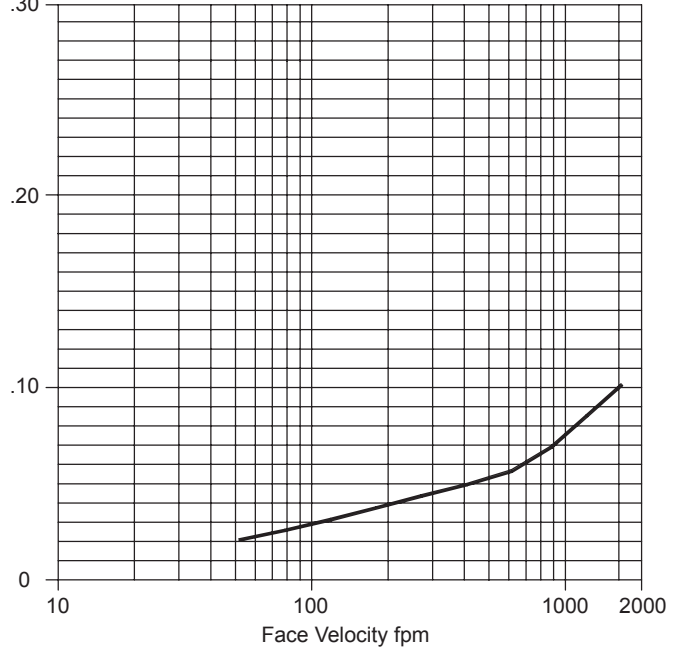

**Air Leakage:** Air leakage quantities shown in the chart are results of tests per AMCA standard 500 and are shown at .1 in.wg differential pressure and corrected to .075 lbs/cu.ft. air density.

Total CFM Air Leakage at .10" Static Pressure Differential Through Closed Damper

		Width						
		12	18	24	30	36	42	48
Height	12	6.6	9.9	13.2	16.5	19.8	23.1	26.4
	24	13.2	19.8	26.4	33.0	39.6	46.2	52.8
	36	19.8	29.7	39.6	49.5	59.4	69.3	79.2
	48	26.4	39.6	52.8	66.0	79.2	92.4	105.6
	60	33.0	49.5	66.0	82.5	99.0	115.5	132.0
	72	39.6	59.4	79.2	99.0	118.8	138.6	158.4

For determining leakage values greater than .10 in.wg to a maximum 2 in.wg use the multiplier correction chart below.

Static Pressure	.2	.3	.4	.5	1.0	1.5	2.0
Multiplier Correction Factor	1.07	1.12	1.19	1.24	1.66	1.92	2.10

Air leakage ratings are based on AMCA Standard 500 using test set up Fig. 5.4 with damper in the closed position without the aid of a counterweight or other mechanical means to provide closing torque, for a size 42"W x 42"H damper with blade and jamb seals.

