

# MODEL ER

Raised Cant Equipment Support • Aluminum or Steel

## STANDARD MATERIALS AND CONSTRUCTION

### Formed Aluminum Curb

**SHELL &** .063" thick aluminum alloy 3003-H14; All seams

**BASE PLATE:** are fully welded and sprayed with protective coating

**INSULATION:** 1" semi-rigid fiberglass

**CANT:** Mitered 3" x 3" integral cant

**REINFORCEMENTS:** On 12" centers

**NAILER:** Varies by width, factory installed

**FINISH:** Mill

### Formed Steel Curb

**SHELL &** 18-GA galvanized steel; All seams are fully

**BASE PLATE:** welded and sprayed with protective coating

**INSULATION:** 1" semi-rigid fiberglass

**CANT:** Mitered 3" x 3" integral cant

**REINFORCEMENTS:** On 12" centers

**NAILER:** Varies by width, factory installed

**FINISH:** Mill

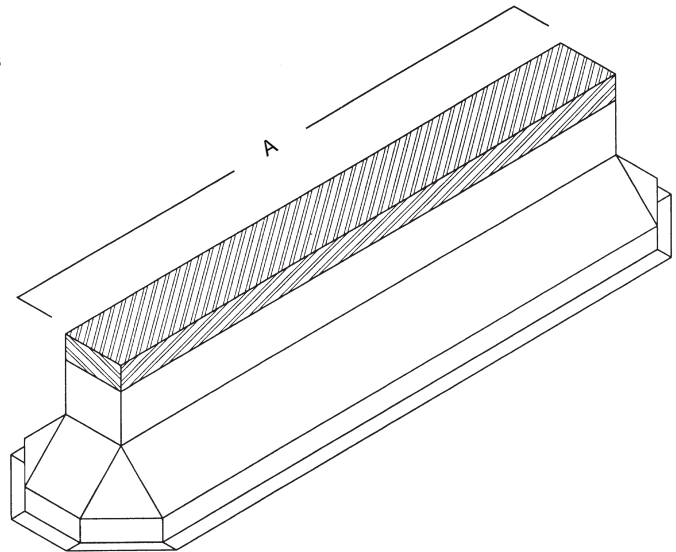

## OPTIONS

**Material Aluminum** - Available in .081-.125 thick 3003-H14 alloy

**Material Steel** - Available in various gauges of galvanized, galvaneal or stainless

**Pitched or Peaked** - In conjunction with the overall dimensions, both the height rise, specified in linear inches per foot (ex: 3" in 12") and the direction of the pitch must be specified.

**Counterflashing** - A removable metal cap fabricated of the same material as the equipment support provides for an effective method of attaching roofing felts.

**Gasket** - 1/4" thick polyurethane foam gasket can be installed, lining the entire top perimeter. Gasket can be used in place of, or in addition to a wood nailer.

**Finishes** - A wide selection of finishes include baked enamel, epoxy, or prime coat. Aluminum curb finishes include Kynar, clear or color anodize.

## NOTES

1. "A" and "B" are opening dimensions.
2. If either dimension exceeds 90", multi-section construction may be required.

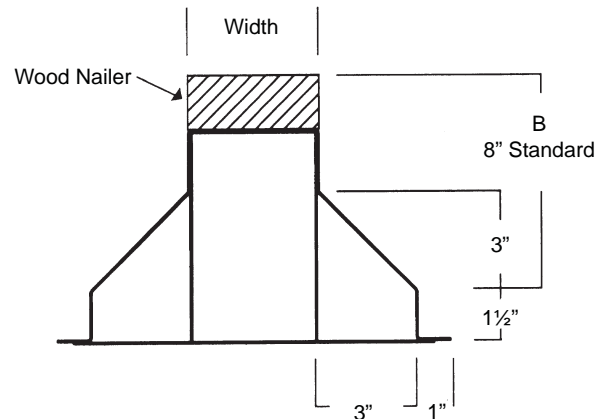

## EQUIPMENT SUPPORT WIDTH

Nominal Width	Actual Nailer Width
4"	3 1/2"
6"	5 1/2"
8"	7 1/2"
10"	9 1/2"
12"	11 1/2"

air balance

Dampers  Louvers  
UL Life Safety Products  
Division of Mestek  
Member of AMCA

# MODEL ER

Raised Cant Equipment Support • Aluminum or Steel

This page intentionally left blank.

air balance

Dampers  Louvers  
UL Life Safety Products  
Division of Mestek  
Member of AMCA