

MODEL ERAC
RAISED CANT EQUIPMENT SUPPORT
FORMED ALUMINUM

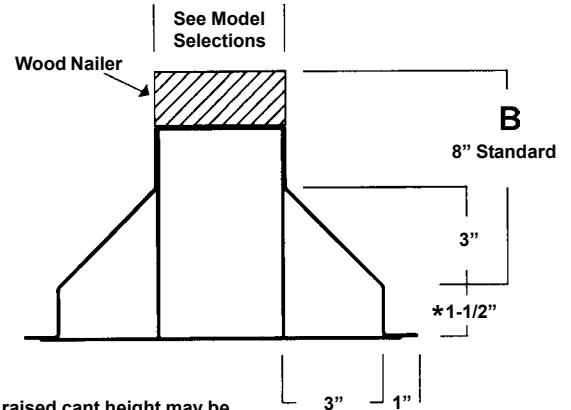
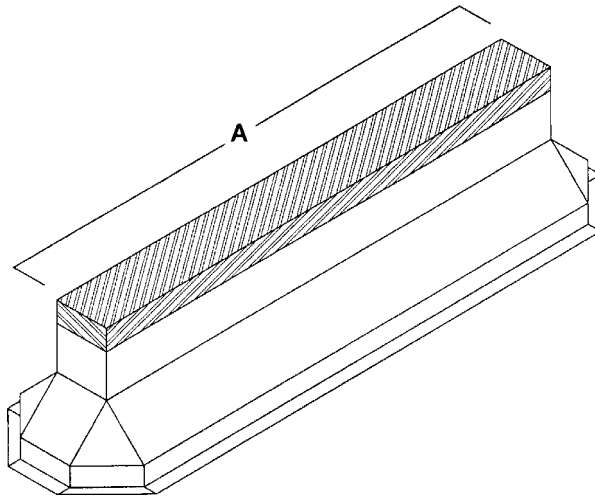

*Standard raised cant height may be increased or decreased by specifying

| Qty. | 'A' | 'B' | Options / Accessories | Tag |
|------|-----|-----|-----------------------|-----|
| | | | | |
| | | | | |
| | | | | |
| | | | | |

STANDARD CONSTRUCTION

- Fabricated of .063" thick aluminum alloy 3003-H14 shell and base plate. All seams are fully welded and sprayed with protective coating.
- Incorporates a mitered 3" x 3" integral cant raised 1-1/2".
- Internal reinforcements at 12" centers.
- Factory installed wood nailer for equipment mounting (Mechanically fastened.)
- Mill finish is standard.
- Lengths exceeding 90" may require multiple section construction.

| MODEL SELECTIONS | | |
|-------------------------|---------------|---------------------|
| | NOMINAL WIDTH | ACTUAL NAILER WIDTH |
| ERAC-04 | 4" | 3-1/2" |
| ERAC-06 | 6" | 5-1/2" |
| ERAC-08 | 8" | 7-1/2" |
| ERAC-10 | 10" | 9-1/2" |
| ERAC-12 | 12" | 11-1/2" |

PROJECT: _____
 LOCATION: _____
 ARCHITECT: _____
 ENGINEER: _____
 CONTRACTOR: _____
 PO NUMBER: _____
 DATE: _____

OPTIONS / ACCESSORIES

MATERIAL

Aluminum products are available in either .081" or .125" thick 3003-H14 alloy.

PITCHED OR PEAKED

All units are available as pitched or peaked. In conjunction with the overall unit dimensions, both the height rise, specified in linear inches per foot (e.g. 3" in 12") and the direction of the pitch must be specified.

COUNTERFLASHING

A removable metal cap fabricated of the same material as the equipment support provides for an effective method of attaching roofing felts.

GASKET

1/4" thick polyurethane foam gasket can be installed, lining the entire top perimeter. Gasket can be used in place of, or in addition to a wood nailer.

FINISHES

A wide selection of finishes including baked enamel, epoxy, Kynar, clear or color anodize, or prime coat.