

# MODEL FS1

Class I • 250°F or 350°F • 1½ Hour • Galvanized Steel • Single Thickness Blade • Combination Fire/Smoke Damper

## STANDARD MATERIALS AND CONSTRUCTION

- FRAME:** 5½" x 7⁄8" x 16-GA galvanized steel hat channel; Flat 16-GA galvanized head and sill for maximum free area on dampers ≤ 13" high
- BLADES:** 16-GA galvanized steel single thickness; Parallel action
- AXLES:** Plated solid steel stub
- BEARINGS:** Oil impregnated bronze
- LINKAGE:** Plated steel angle and crank plates with stainless steel pivots, in-jamb type or on-blade type
- STOPS:** 18-GA galvanized steel angles at head and sill
- BLADE SEALS:** Silicone
- JAMB SEALS:** Stainless steel
- SLEEVE:** Minimum 20-GA galvanized steel by 18" long (sizes greater than 84" wide or 84" high require minimum 18-GA)
- CAULKING:** Hardcast Irongrip 601 or UL-listed equivalent
- ACTUATOR:** Electric with heat response device (EHRD) or pneumatic with heat response device (PHRD); Factory-installed for Power-Open/Spring-Close (fail close) operation; External left hand mounted as viewed from jackshaft side of damper
- FINISH:** Mill

## OPTIONS

- Exact Size
- Sleeve - Transition
- Actuators - 120V, 24V, 230V or Pneumatic
- Right Hand and/or Internal Actuator Mounting Locations (Restrictions Apply)
- Integral Dual Position Indication (IDPI) Switches
- Sensotherm Re-Openable Heat Response Device (ESOT) for Electric Actuator
- Sensotherm Re-Openable Heat Response Device (EPOT) for Pneumatic Actuator
- Model SM-501 Flow-Rated Smoke Detector (10" Minimum Damper Height)
- Model 2151 No-Flow Smoke Detector (12" Minimum Damper Height)
- Remote Test Box
- Transformers
- Copper Tubing (For Pneumatic Actuators)
- Tab-Lock Retaining Angles - 1 or 2 Sets
- Bearings - Stainless Steel
- Axle - Stainless Steel
- Security Bars
- Short-Width (<16") and/or Short-Height (<8") Transitions

## NOTES

1. "A" width and "B" height are opening dimensions. Dampers are provided approximately ¼" undersize.
2. Damper with smoke detector must have a minimum sleeve of 19" (10.5" on the actuator side and 3" on the non-actuator side).
3. Dampers for horizontal installation can only be mounted in a fire barrier constructed of masonry/concrete material.

## DAMPER SIZES

		2000 fpm, 4 in.wg						3000 fpm, 4 in.wg		
Orientation	Hor & Vert	Horizontal		Vertical				Hor & Vert	Horizontal	Vertical
Panels	Minimum Panel	Max Panel 250°/350°	Max Assy 250°/350°	Max Panel 250°	Max Panel 350°	Max Assy 250°	Max Assy 350°	Max Panel 250°	Max Assy 250°	Max Assy 250°
Rectangular	4"W x 4"H (16"W x 8"H frame)	36"W x 48"H	72"W x 48"H	36"W x 48"H 48"W x 36"H	36"W x 48"H	144"W x 70"H	128"W x 62"H	36"W x 36"H	72"W x 36"H	108"W x 36"H
Round	4" dia. (16"W x 8"H frame)	34" dia.	46" dia.	34" dia.	34" dia.	68" dia.	60" dia.	34" dia.	34" dia.	34" dia.
Oval	4"W x 4"H (16"W x 8"H frame)	34"W x 46"H	70"W x 46"H	34"W x 46"H 46"W x 34"H	34"W x 46"H	45 sq.ft 106"W or 68"H	106"W x 60"H	34"W x 34"H	70"W x 34"H	106"W x 34"H

\*Dampers smaller than minimum frame size require a transitions. Reference SD-TRFS.

**UNDERWRITERS LABORATORIES INC.®**  
 CLASSIFIED DYNAMIC FIRE AND SMOKE DAMPER  
 FIRE RESISTANCE RATING 1½ HR  
 LEAKAGE RESISTANCE CLASS I

abi air balance **FILE #R4708**

This combination fire/smoke damper meets the construction and performance requirements of:

- Underwriters Laboratories Inc. Standard 555S
- National Fire Protection Association Standards 80 and 90A
- ICC's International Building Code
- California State Fire Marshal Listing #3225-1328:119
- Underwriters Laboratories Inc. Approved for dual direction airflow and dynamic conditions.
- Underwriters Laboratories Inc. Classified for use in fire resistive ratings of less than 3 hours.
- Underwriters Laboratories Inc. Classified for use in smoke control systems for Leakage Class I and 250°F or 350°F.
- Actuators must be arranged to operate automatically, must fail closed upon loss of power, and must be controlled by a smoke detection system.

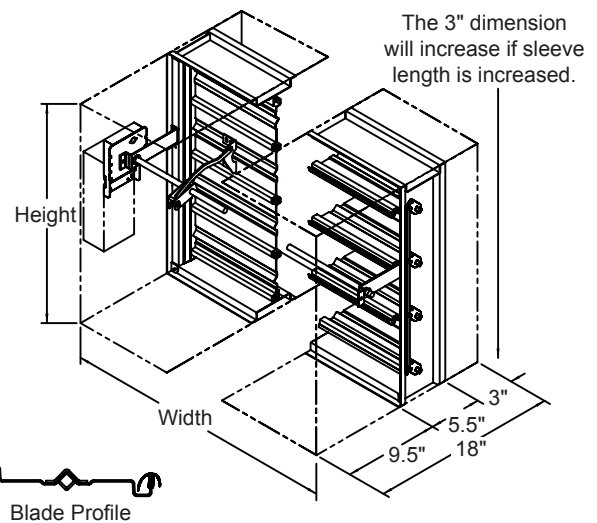

Dampers Louvers  
 UL Life Safety Products  
 Division of Mestek  
 Member of AMCA

# MODEL FS1

Class I • 250°F or 350°F • 1½ Hour • Galvanized Steel • Single Thickness Blade • Combination Fire/Smoke Damper

**Operations Rating:**

Maximum Differential Pressure: 4 in.wg  
 Maximum Face Velocity: 2000 fpm (3000 fpm for selected size/actuator combinations)

**Leakage Rating:**

UL Class I  
 4 cfm per sq.ft. maximum @ 1 in.wg  
 8 cfm per sq.ft. maximum @ 4 in.wg

**Sound Ratings:**

The Noise Criterion data below was tested in accordance with ASTM E477.99 in the center octave band.

Noise Criterion (NC)				
Damper Size	Velocity (fpm)			
	1000	2000	3000	4000
12"W x 12"H	31	53	64	71
24"W x 24"H	33	54	65	n/a

**Pressure Drop Ratings:**

The pressure drop data shown below is based on laboratory conditions. The test setup does not take into account elbows or other duct fittings that are part of every actual duct system. The configuration of the actual duct system immediately upstream and downstream of the damper often contributes more pressure loss than the damper itself.

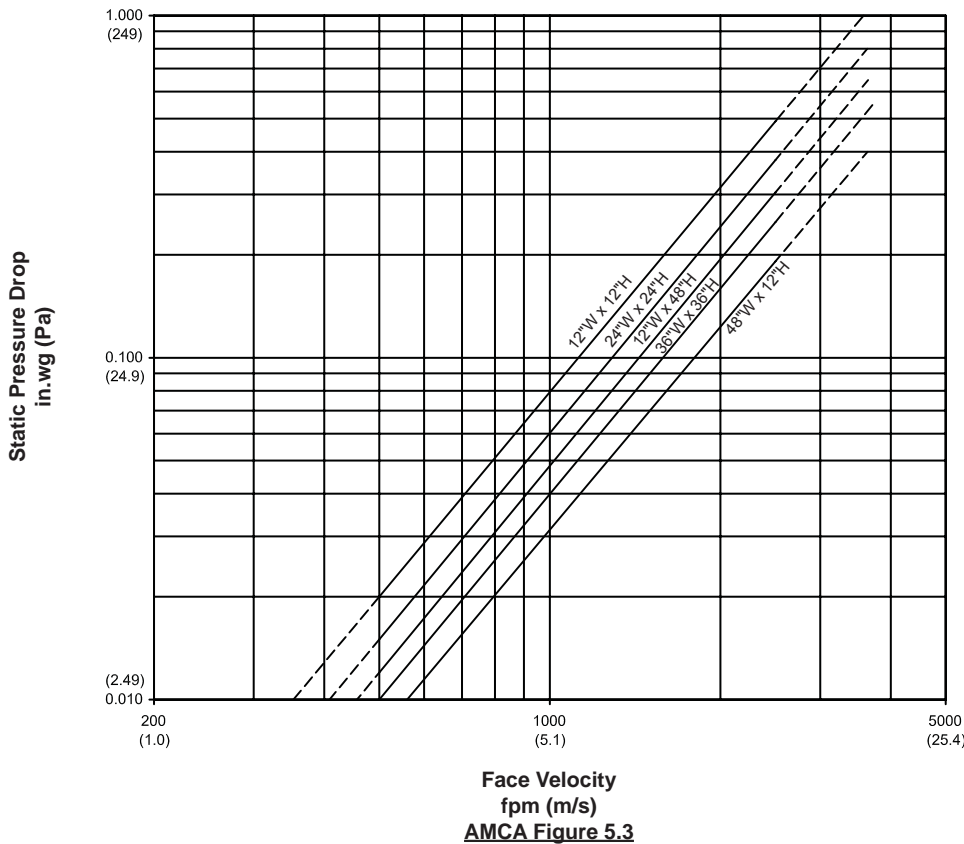

Air Balance certifies that the model FS1 damper shown here is licensed to bear the AMCA seal. The ratings shown are based on tests and procedures performed in accordance with AMCA Publication 511 and comply with the requirements of the AMCA Certified Ratings Program. The AMCA Certified Ratings Seal applies to Air Performance Ratings only.

**air balance**

Dampers  Louvers  
 UL Life Safety Products  
 Division of Mestek  
 Member of AMCA