

# MODEL FSAH

1" Deep • High Pressure Duct Access Door

## STANDARD MATERIALS AND CONSTRUCTION

- FRAME:** 22-GA galvanized steel
- DOOR PANEL:** 24-GA galvanized steel
- INSULATION:** 1" fiberglass
- PRE-FORMED TABS:** 22-GA galvanized steel
- FINISH:** Mill

## OPTIONS

- .032" Aluminum with Plated Steel Cams and Strikers
- 24-GA Stainless Steel with Stainless Steel Cams and Strikers

## NOTES

1. "A" width and "B" height are opening dimensions.
2. Standard construction to 10" Static Pressure.
3. On non standard doors, the height is always the larger dimension.

## DOOR SIZES

Panels	Standard Sizes	FSA100H Cams	FSA101H Cams
FSA	6"W x 6"H	3	4
	8"W x 8"H	3	4
	10"W x 10"H	3	4
	12"W x 12"H	3	4
	14"W x 14"H	3	4
	16"W x 16"H	6	8
	18"W x 18"H	6	8
	20"W x 20"H	6	8
	24"W x 24"H	6	8

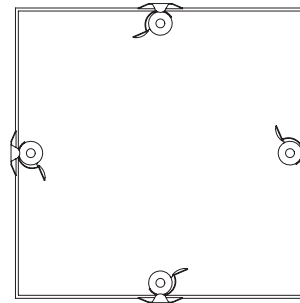

FSA101H

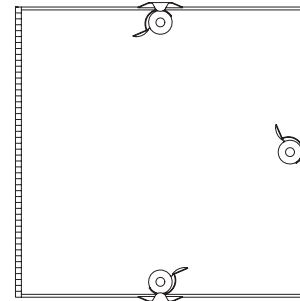

FSA100H

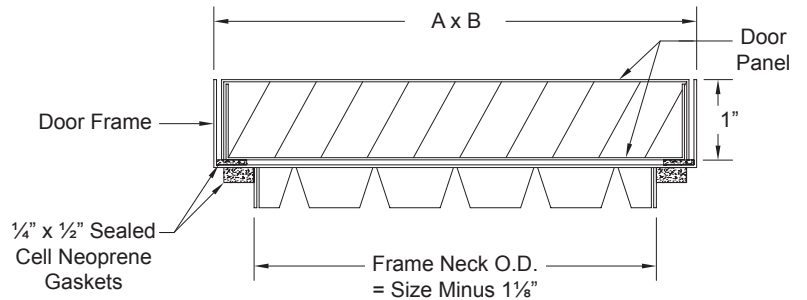

# MODEL FSAH

1" Deep • High Pressure Duct Access Door

This page intentionally left blank.

air balance

Dampers  Louvers  
UL Life Safety Products  
Division of Mestek  
Member of AMCA