

MODEL HA

Hinged Adapter • Aluminum or Steel Curb

STANDARD MATERIALS AND CONSTRUCTION

Formed Aluminum Curb

SHELL & .063" thick aluminum alloy 3003-H14; All seams

BASE PLATE: are fully welded and sprayed with protective coating

HINGES: Heavy duty butt hinges and 2 piece padlock hasp

GASKET: Urethane gasket around perimeter for sealing and water tightness

FINISH: Mill

Formed Steel Curb

SHELL & 18-GA galvanized steel; All seams are fully

BASE PLATE: welded and sprayed with protective coating

HINGES: Heavy duty butt hinges and 2 piece padlock hasp

GASKET: Urethane gasket around perimeter for sealing and water tightness

FINISH: Mill

OPTIONS

Material Aluminum - Available in .081-.125 thick 3003-H14 alloy.

Material Steel - Available in various gauges of galvanized, galvaneal or stainless.

Finishes - A wide selection of finishes include baked enamel, epoxy, or prime coat. Aluminum curb finishes include Kynar, clear or color anodize.

NOTES

1. "A" width, "B" length are outside dimensions.
2. Maximum size is 60"W x 60"H.

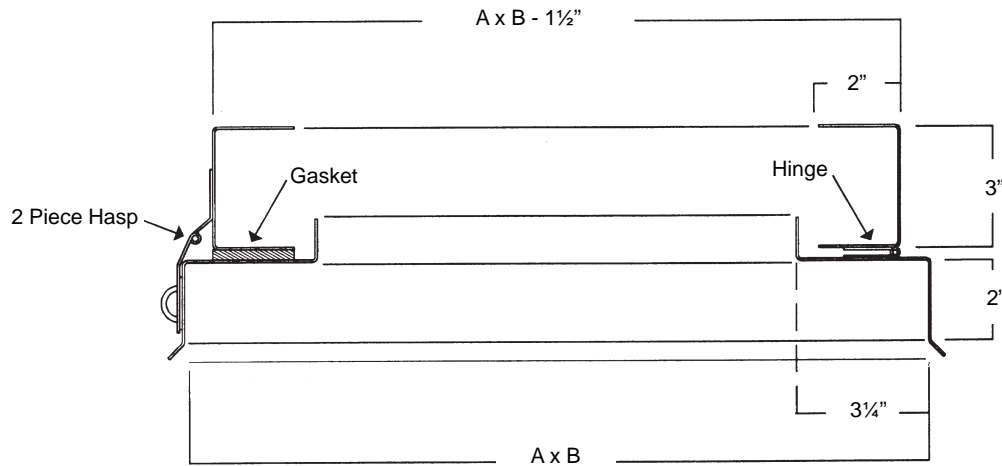
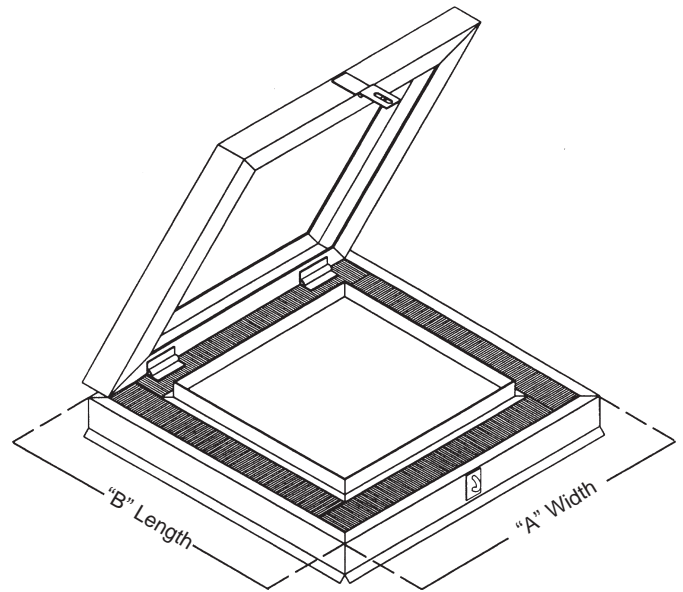

air balance

Dampers  Louvers
UL Life Safety Products
Division of Mestek
Member of AMCA

MODEL HA

Hinged Adapter • Aluminum or Steel Curb

This page intentionally left blank.