

MODEL ID51

10" Deep • Airfoil Blade • 450°F Max. Temperature • Up to 20 in.wg Static Pressure • Industrial Damper

STANDARD MATERIALS AND CONSTRUCTION

- FRAME:** 2" x 10" x 2" - 10-GA galvanized steel formed channel frame
- BLADE:** 12-GA airfoil for dampers < 48"W; 10-GA airfoil for dampers 48"W - 60"W
- SHAFTS:** 3/4" dia. corrosion resistant, plated cold finished steel for dampers < 48"W; 1" dia. for dampers 48"W - 60"W
- BEARINGS:** Stainless steel flanged sleeve, bolted to frame
- LINKAGE:** 1/2" dia. inter-connecting rod with trunnion pivot fastener; Located in jamb
- OPERATOR:** Manual hand quadrant or lever arm for electric or pneumatic actuator
- FINISH:** Mill
- TEMP. LIMITS:** 450°F; Consult factory for temp. > 450°F

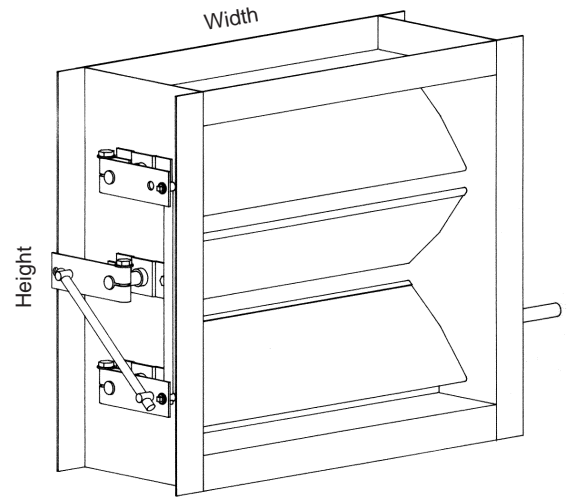

OPTIONS

- Stainless Steel Blade Edge Seals or Jamb Seals
- Stuffing Boxes and Replaceable Packing
- Variable Flange Sizes
- Finish - Baked Enamel, Kynar, Anodize
- Perimeter Holes - One Flange or Both Flanges
- Other Material

NOTES

1. "A" width and "B" height are opening dimensions. Dampers are provided by inside dimension.

DAMPER SIZES

Panels	Min Panel (ID)	Max Single Panel (ID)
ID51	6"W x 6"H Single Blade 6"W x 12"H Opposed Blades	60"W x 96"H

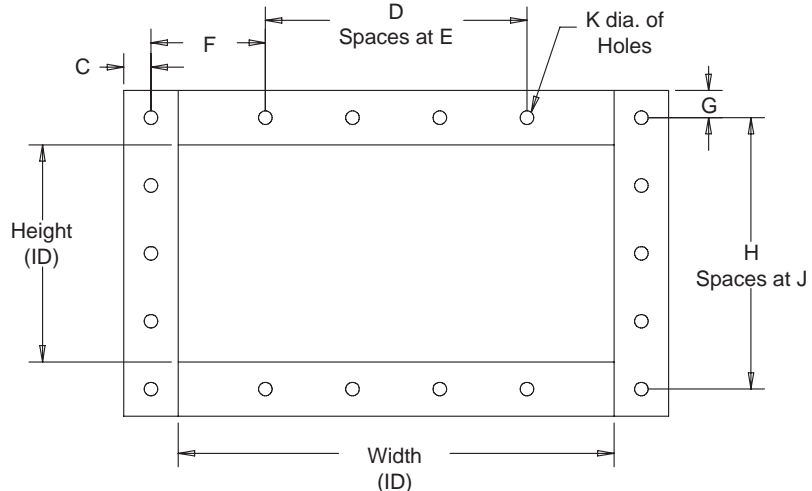
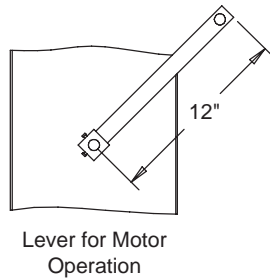
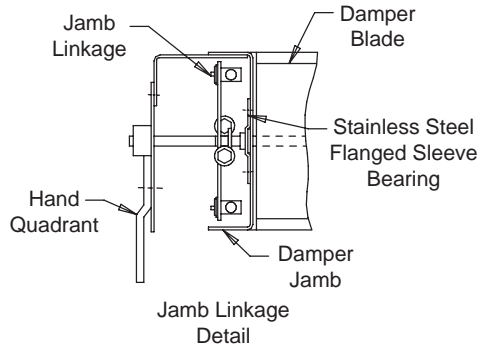
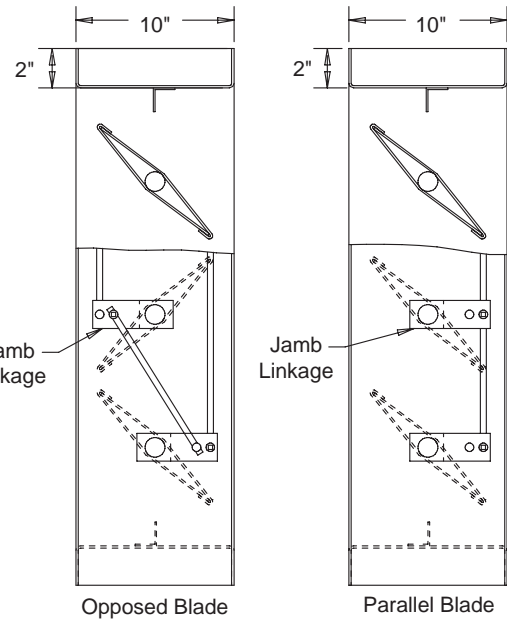

Optional Flange with Holes
(Must Specify Dimensions C-K)

MODEL ID51

10" Deep • Airfoil Blade • 450°F Max. Temperature • Up to 20 in.wg Static Pressure • Industrial Damper

Free Area:

Pressure drop curves listed are based on AMCA Standard 500, using test set up Fig. 5.3 for damper installed with duct upstream and downstream. Static pressures are corrected to .075 lb/cu.ft air density.

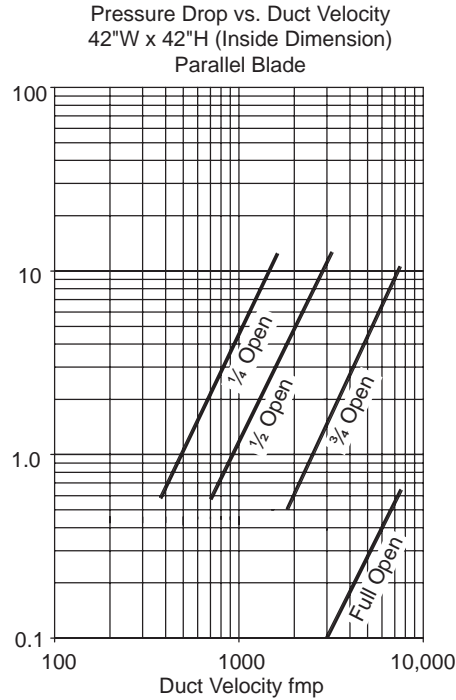
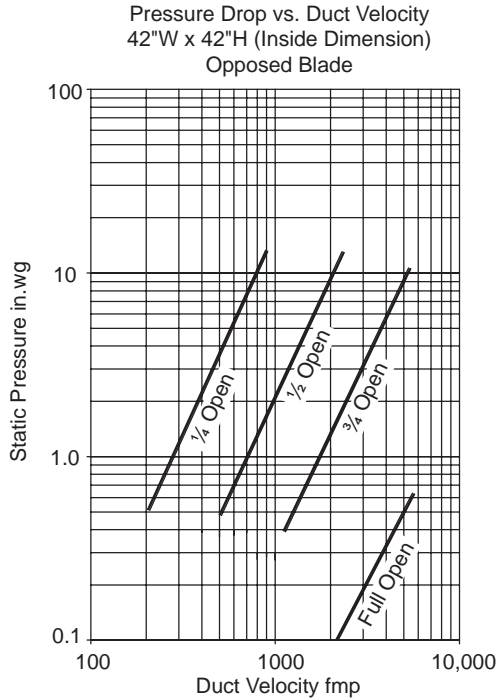

Air Leakage:

Air leakage quantities show in the chart are results of tests per AMCA Standard 500 and are shown at 1 in.wg differential pressure and corrected to .075 lb/cu.ft. air density.

Air Leakage cfm

		Width								
		12	18	24	30	36	42	48	54	60
Height	12	5	7	10	12	14	17	19	22	24
	24	10	14	19	24	29	34	39	43	48
	36	14	22	29	36	43	51	58	65	72
	48	19	29	39	48	58	68	77	87	96
	60	24	36	48	60	72	84	96	108	121
	72	29	43	58	72	87	101	116	130	145
	84	32	51	68	84	101	118	135	152	169
	96	39	58	77	96	116	135	154	174	193

Air leakage ratings are based on AMCA Standard 500 using test set up 5.4 with a damper closing torque applied to the damper of 75 in.lb/sq.ft. of damper area for a size 60"W x 96"H, with a minimum of 55 in.lb/sq.ft. of damper area for a size 60"W x 8"H.

Damper air leakage show is based upon publishing only the most conservative leakage results for the ABI Model ID51 Industrial Damper for an entire range of damper sizes.

To ensure proper damper operation and air leakage performance for this damper design. The static pressure/blade length limits shown provide the user with this information and in addition provides a relationship between damper cost and the application.

For determining leakage values greater than 1 in.wg to a maximum of 20 in.wg use the multiplier correction chart below.

Static Pressure	2	3	4	5	6	7	8	9	10	11	12	13	14	15	16	17	18	19	20
Multiplier Correction Factor	1.3	1.6	1.9	2.2	2.4	2.6	2.8	3.0	3.2	3.3	3.5	3.6	3.7	3.9	4.0	4.1	4.2	4.4	4.5

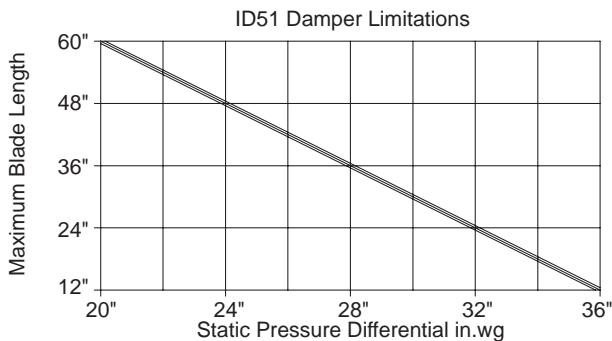

The ID51 damper design at a blade length of 6" has a maximum allowable blade deflection of L/360 for the static pressure indicated on the chart. At reduced blade lengths higher static pressure limits can be attained without sacrificing damper operating and performance characteristics.

In the interest of product development, Air Balance reserves the right to make changes without notice.

P.O. Box 606 • 7435 Industrial Rd. • Florence, KY 41042 • Phone: (859) 538-3400 • Fax: (859) 647-7810

