

# MODEL MD39

Non-Motorized • Single Thickness Blade • 3 Hour • Dynamically Rated • UL Classified Fire Damper

## STANDARD MATERIALS AND CONSTRUCTION

- FRAME:** 5½" x 7⁄8" x 16-GA galvanized steel hat channel
- BLADES:** 16-GA galvanized steel, 6" nominal width, parallel action
- AXLES:** Square, plated solid steel stub
- BEARINGS:** Oil impregnated bronze
- LINKAGE:** Plated steel angle and crank plates with stainless steel pivots in-jamb type
- STOPS:** 18-GA galvanized steel at head and sill
- JAMB SEALS:** Stainless Steel
- FINISH:** Mill
- ACTUATOR:** Non-motorized spring closure mechanism with 165°F fusible link

## UNDERWRITERS LABORATORIES INC.®

CLASSIFIED DYNAMIC FIRE DAMPER  
 FIRE RESISTANCE RATING 3 HR  
 IN ACCORDANCE WITH UL-555  
 SEE U.L. FIRE RESISTANCE DIRECTORY

abi air balance

FILE #R4708



This fire damper meets the construction and performance requirements of:

- Underwriters Laboratories Inc. Standards 555
- National Fire Protection Association Standards 80 and 90A
- ICC's International Building Code
- Underwriters Laboratories Inc. Approved for dual direction airflow and dynamic conditions.
- Underwriters Laboratories Inc. Classified for use in fire resistive ratings of 3 hours or more.

## OPTIONS

- Sleeve of various depths (16" minimum) and gauges
- Round or oval transitions
- 212°F fusible link
- Dual position indication package (see note #2.)

## NOTES

1. "A" width and "B" height are opening dimensions. Dampers are provided ¼" undercut.
2. Optional auxiliary blade position indication switches are rated at 11A, 1/3HP, 125VAC. These snap action switches are intended to make or break a circuit and will not provide variable or proportional resistance.

## DAMPER SIZES

Orientation	Hor & Vert	2000 fpm, 4 in.wg				4000 fpm, 4 in.wg	
		Horizontal (floor)		Vertical (wall)		Horizontal (floor)	Vertical (wall)
Panels	Min Panel	Max Single Panel	Max Assy Panel	Max Single Panel	Max Assy Panel	Max Single Panel	Max Single Panel
Rectangular	4"W x 4"H (8"W x 8"H frame)	30"W x 48"H 36"W x 30"H	60"W x 48"H	36"W x 48"H	126"W x 48"H	30"W x 48"H 36"W x 30"H	36"W x 48"H
Round	6" dia. (8"W x 8"H frame)	28" dia.	46" dia.	34" dia.	46" dia.	28" dia.	34" dia.
Oval	6"W x 6"H (8"W x 8"H frame)	28"W x 46"H 34"W x 28"H	58"W x 46"H	34"W x 46"H	124"W x 46"H	28"W x 46"H 34"W x 28"H	34"W x 46"H

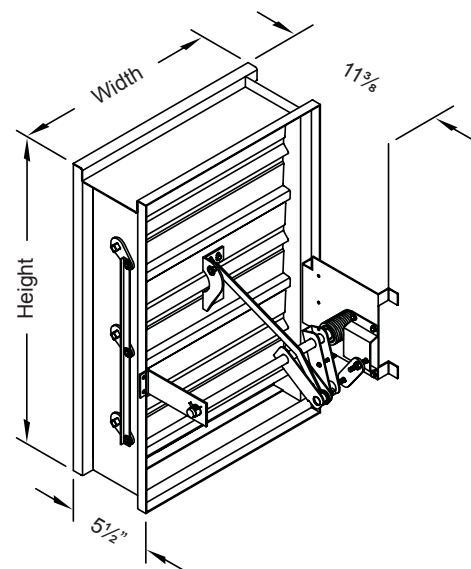

air balance

Dampers Louvers  
 UL Life Safety Products  
 Division of Mestek  
 Member of AMCA

# MODEL MD39

Non-Motorized • Single Thickness Blade • 3 Hour • Dynamically Rated • UL Classified Fire Damper

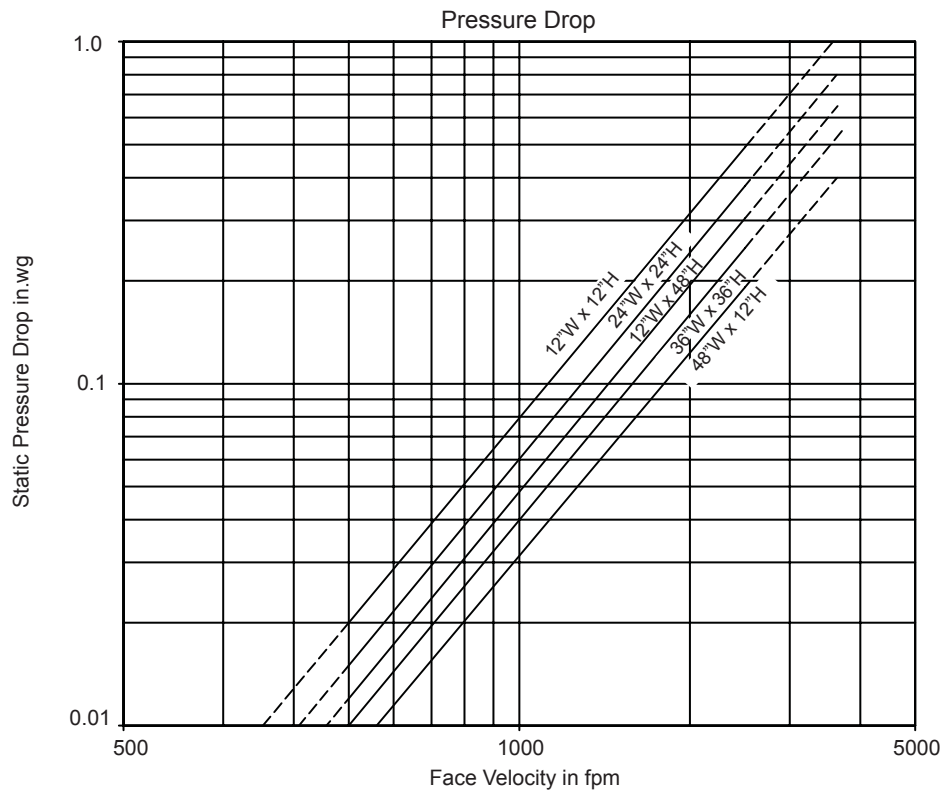

Typical Performance Curve  
Tested per AMCA Standard 500-D; Figure 5.3 (In-Duct Mount)  
(Smaller sizes will have higher pressure drops.)