

MODEL P465P/P655P

4" or 6" Deep • Straight Blade • Post Corner • Extruded Aluminum Penthouse

STANDARD MATERIALS AND CONSTRUCTION

FRAME: .081" thick nominal; 6063-T6/T52 extruded aluminum alloy with reinforcing rib bosses

BLADES: .081" thick nominal; 6063-T6/T52 extruded aluminum alloy with reinforcing rib bosses

ROOF: Removable roof .060" thick sheet aluminum reinforced with aluminum bracing where required to take a snow load of 40 lbs/sq.ft. plus a required safety factor

INSULATION: 1/2" thick insulation on underside of roof

SCREEN: 1/2" x .051" flattened galvanized birdscreen

FINISH: Mill

OPTIONS

Finish - Baked Enamel, Kynar, or Anodize

Variety of Bird and Insect Screen

.125" Nominal Construction

Sloped Roof

NOTES

1. "A" width and "B" height are opening dimensions. Penthouse dimensions "A" or "B" exceeding 84" shall be shipped in section for field assembly by others.

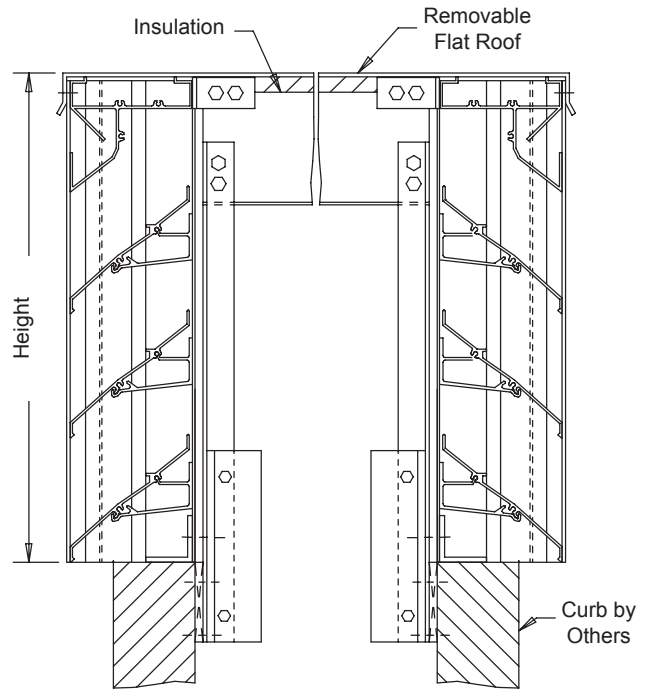

Angles - All Corners and Intermediate, to Extended from Roof into Curb

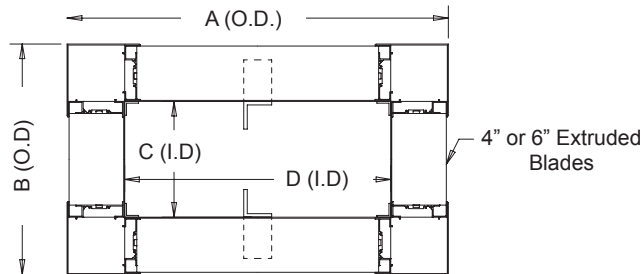
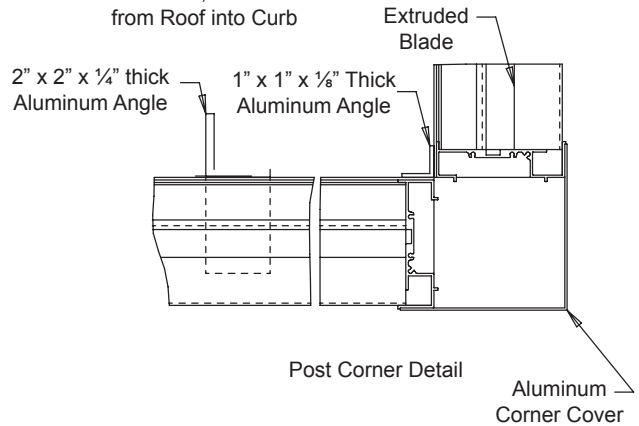
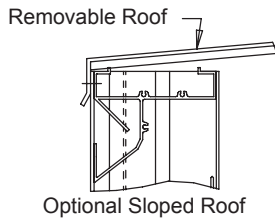

Continuous Angles at the Four Corners and Intermediate as Required

air balance

Dampers  Louvers
UL Life Safety Products
Division of Mestek
Member of AMCA

MODEL P465P/P655P

4" or 6" Deep • Straight Blade • Post Corner • Extruded Aluminum Penthouse

This page intentionally left blank.

air balance

Dampers  Louvers
UL Life Safety Products
Division of Mestek
Member of AMCA