

PK1200 & PK1201

Fire/Smoke Damper Models: FR, CR, MR, AR, FS, CG, MS, AS, FT, CH, MT, AT, FA, CA, MA, UA, TA, CT, LA

Smoke Damper Models: SR, SR, KR, UR, S, SG, KH, A, SA, GA, KA, AA

APPLICATION

The switch package is mechanically connected to either a control damper blade (Model PK1200) or to an external damper axle or extended shaft (Model PK1201). Rotation of the damper blade or shaft rotates the switch cam which makes or breaks the electrical contacts of the two switches. One switch indicates damper closure and the other switch indicates the damper being opened. Each switch has three differently colored leads, one each coming for the common, normally opened and normally closed contacts. The dry contacts can be used to remotely indicate damper blade position status (open or closed) and/or be used to turn on or off fans and other devices that are dependent on damper blade position.

MICRO SWITCH SPECIFICATIONS

Temperature Rating: -67°F to 180°F (-55°C to 82°C)

Single-Pole, Double-throw

AMP Ratings and 1/3 hp at 125, or 277 VAC

1/2 AMP at 125 VDC

1/4 AMP at 250 VDC

10 AMPS at 24 VDC

4 AMPS at 125 VAC "L" (lamp load)

PK1200 (Fig. 1)

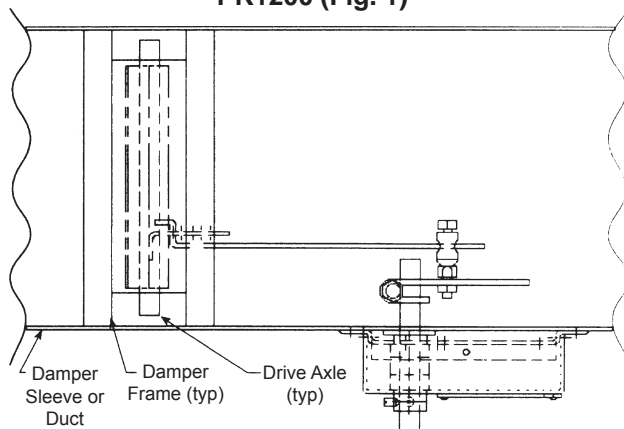

PK1201 (Fig. 2)

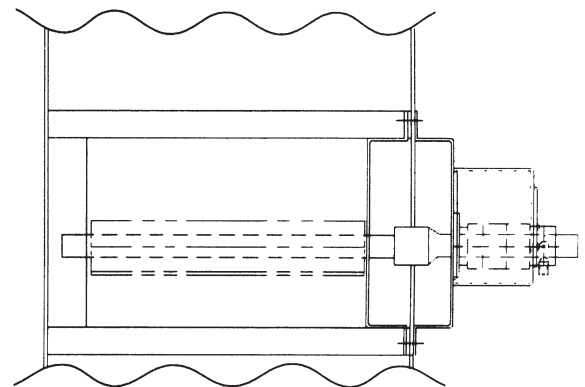

DIMENSIONAL AND WIRING DETAILS (Fig. 3)

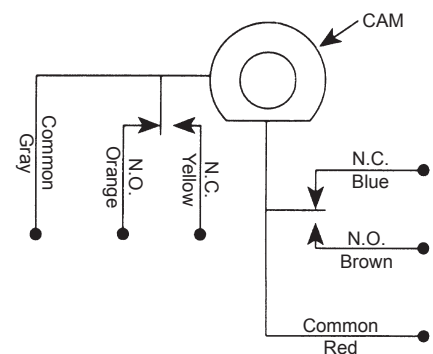
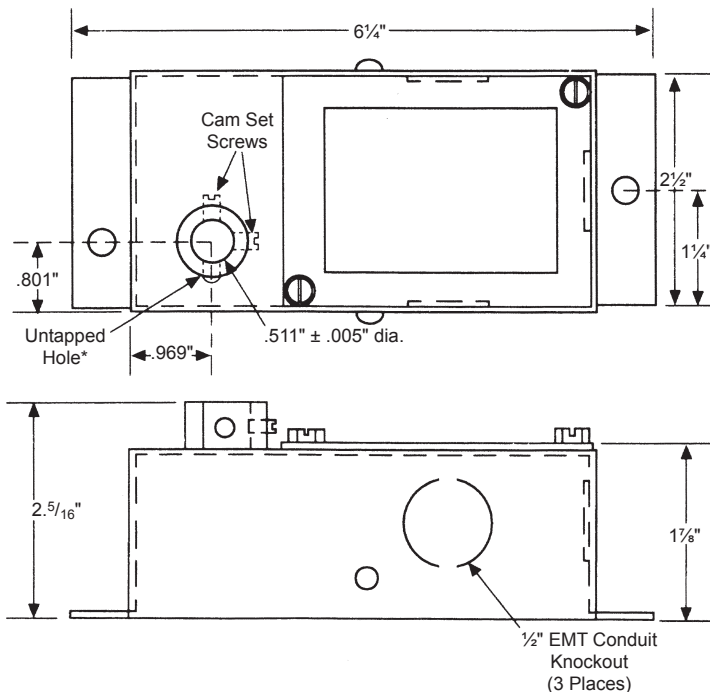

NOTES:

1. Bottom switch provides a contact closure to positively indicate the damper in full-closed position.
2. Top switch provides a contact closure to positively indicate the damper in full-open position.
3. The above wiring schematic is shown with the damper in full-closed cam set-up position.

*Indicates cam set-up orientation. Untapped cam hole lines up with notch in the position box.

PK1200 & PK1201

Fire/Smoke Damper Models: FR, CR, MR, AR, FS, CG, MS, AS, FT, CH, MT, AT, FA, CA, MA, UA, TA, CT, LA

Smoke Damper Models: SR, SR, KR, UR, S, SG, KH, A, SA, GA, KA, AA

PK1200

This is offered for most control dampers, but can be supplied for smoke and combination fire/smoke dampers, also. It is designed to provide signal for full-open or full-closed based on 90° of rotation. It is a stand-alone device that provides the necessary parts to mount a wiring housing to the duct or sleeve near the damper blade, which is then mechanically interconnected to the blade. Because of the direct attachment to the blade, this method provides the most certainty that accurate position is monitored. This is also used when position indication is not ordered with the product, but is required for product in the field.

Blade Actuated Mounting Instructions (Fig. 1)

Parts Included:

- | | | |
|------------------------------------|--------------------------------|----------------------------|
| 1. Position Indication Box (Qty 1) | 4. Blade Clip (Qty 1) | 7. Foam Gasket (Qty 1) |
| 2. Crank Arm (Qty 1) | 5. Linkage Rod (Qty 1) | 8. Shaft (½" x 6") (Qty 1) |
| 3. Ball Joint (Qty 1) | 6. Self-Drilling Screw (Qty 6) | |

- Select damper blade on which blade clip (item 4) is to be mounted. Top of blade should be open toward end switch. Top of blade should open toward end switch.
- Attach blade clip to blade using two self drilling screws (item 6). Blade clip centerline should be approximately 2" above centerline of blade axle. Locate bracket approximately 3" from end of blade.
- Locate and drill a ¾ diameter hole in the duct or sleeve approximately 10-12" from the blade. The drilled hole should be located the same distance from the top or bottom of the damper frame as is the axle of the damper blade to which the blade clip has been fastened.
- Remove paper backing from the shaft gasket (item 7) and attach to the duct or sleeve, centering it over the hole drilled from Step 3.
- Insert 6" shaft (item 8) through cam of position indication box (item 1), and through gasket and hole from step 4. Revolve position indication box around cam to desired position and attach using two self-drilling screws (item 6) through the mounting holes at each end of the indication box.
- Attach the crank arm (item 2) to the shaft (item 8) so that it extends approximately 3" beyond the inside edge of the damper frame.
- Attach the ball joint (item 3) to the crank arm approximately 2" from the center of the shaft.
- Insert the crimped end of the linkage rod (item 5) through the blade clip and the straight end through the hole in the ball joint.
- With the damper blades in closed position, rotate the cam and align the untapped hole in can with the notch in the position indication box (Fig. 3)
- Tighten the two set screws in the cam, DO NOT OVER-TIGHTEN.
- Loosen cover screws and open cover on position indication box to expose connecting wire.

NOTE: The cam is designed to trip the position switches at each end of a 90° rotation. A continuity tester may be required to check switch operation. Minor adjustments in the linkage set-up may be required.

PK1201

This is offered for most control dampers, but can be supplied for smoke and combination fire/smoke damper, also. It is designed to provide a signal of full-open or full-closed based on 90° of rotation. It is a stand-alone device that can accept and lock onto a ½" diameter shaft (typically, ½" diameter jackshaft or ½" diameter extended shaft). The housing must be anchored to some fixed support.

Extended Shaft Mounting Instructions (Fig. 2)

Parts Included:

- | | |
|------------------------------------|--------------------------------|
| 1. Position Indication Box (Qty 1) | 2. Self-Drilling Screw (Qty 1) |
|------------------------------------|--------------------------------|

- Locate extended ½" diameter axle, or extended shaft, on which position indicator is to be mounted.
- Slide position indicator box (item 1) onto shaft, allowing shaft to go through the cam. NOTE: If an extended shaft actuator with mounting plate is also placed on this shaft then slide the plate on first and the position indicator box second.
- Revolve position indication box around cam to desired position and attach using one self-drilling screw (item 2) through the hole in the flange that is farthest from the cam.
- With the damper blades in closed position, rotate the cam and align the untapped hole in can with the notch in the position indication box (Fig. 3)
- Tighten the two set screws in the cam, DO NOT OVER-TIGHTEN.
- Loosen cover screws and open cover on position indication box to expose connecting wire.