

MODEL SR2

Class II • 250°F or 350°F • Galvanized Steel • Single Thickness Blade • Smoke Damper

STANDARD MATERIALS AND CONSTRUCTION

- FRAME:** 20-GA galvanized steel flat by 18" long integral sleeve
- BLADES:** 16-GA galvanized steel single thickness; Parallel action
- AXLES:** Plated solid steel stub
- BEARINGS:** Oil impregnated bronze
- LINKAGE:** Galvanized steel angle interconnect, with plated steel brackets and pivots located on blade
- STOPS:** 18-GA galvanized steel at head and sill
- BLADE SEALS:** Silicone
- JAMB SEALS:** Stainless steel
- SLEEVE:** Integral 20-GA galvanized steel by 18" long
- RETAINING ANGLES:** 7/8" x 1 1/2" x 16-GA adjustable perimeter mounting angle
- CAULKING:** Hardcast Irongrip 601 or UL-listed equivalent
- FINISH:** Mill on galvanized steel
- ACTUATOR:** Electric or pneumatic; Factory-installed for Power-Open/Spring-Close (fail close) operation; External left hand mounted as viewed from jackshaft side of damper

UNDERWRITERS LABORATORIES INC.®
 CLASSIFIED SMOKE DAMPER
 LEAKAGE RESISTANCE CLASS II



abi
air balance

FILE #R4708



This smoke damper meets the construction and performance requirements of:

- Underwriters Laboratories Inc. Standard 555S
- National Fire Protection Association Standards 80 and 90A
- ICC's International Building Code
- California State Fire Marshal Listing #3230-1328:121
- Underwriters Laboratories Inc. Approved for dual direction airflow and dynamic conditions.
- Underwriters Laboratories Inc. Classified for use in smoke control systems for Leakage Class II and 250°F or 350°F.
- Actuators must be controlled by a smoke detection system.

OPTIONS

- Integral Dual Position Indication (IDPI) switches
- Model SM-501 Flow-rated smoke detector shipped loose
- Model SM-501 Flow-rated smoke detector mounted and wired (6" minimum damper height with a 20" sleeve - extra 2" on jackshaft side)
- Tab-lock retaining angles
- Stainless steel bearings
- Copper tubing (for pneumatic actuators)
- Optional 19" or 20" sleeve depth - Additional sleeve length is added to the non-jackshaft side unless ordered with mounted smoke detector and/or < 6"H with B-Pan Transition
- Round or oval transitions
- Short-width (<6") and/or short-height (<6") transitions

NOTES

1. "A" width and "B" height are opening dimensions. Damper frames are provided approximately 1/4" undersized.
2. Dampers available in 1" increments only.

DAMPER SIZES

Orientation	Horizontal & Vertical	
	Minimum Panel	Maximum Panel
Rectangular	4"W x 4"H (6"W x 6"H frame)	24"W x 24"H
Round	4" dia. (6"W x 6"H frame)	22" dia.
Oval	4"W x 4"H (6"W x 6"H frame)	22"W x 22"H

*Dampers smaller than minimum frame size require a transition. Reference SD-TRFS. Dampers < 6"H will have a 20" sleeve with the additional sleeve length on the jackshaft side when a B-Pan type transition is ordered.

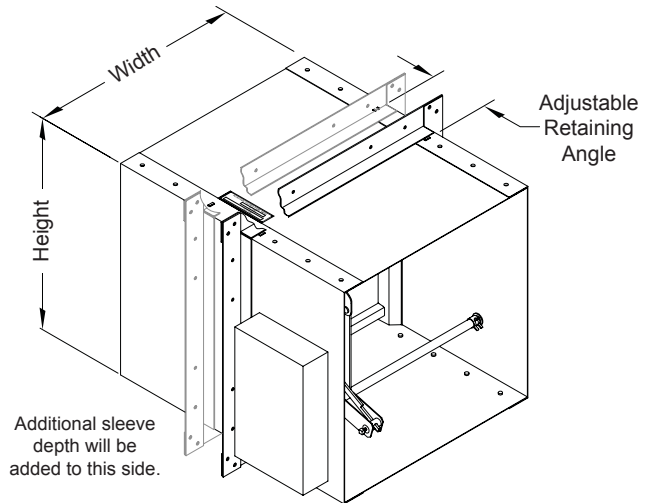

MODEL SR2

Class II • 250°F or 350°F • Galvanized Steel • Single Thickness Blade • Smoke Damper

Operations Ratings:

Maximum Differential Pressure: 4 in. wg
 Maximum Velocity: 2000 fpm

Leakage Ratings:

UL Class II
 20 cfm per sq. ft. maximum @ 4 in. wg

Sound Ratings:

The Noise Criterion data below was tested in accordance with ASTM E477.99 in the center octave band.

Noise Criterion (NC)				
Damper	Velocity fpm (m/s)			
Size	1000 (5.08)	2000 (10.16)	3000 (15.24)	4000 (20.32)
12"W x 12"H (305mm x 305mm)	22dB	44dB	55dB	62dB
24"W x 24"H (305mm x 305mm)	30dB	50dB	62dB	not available

Pressure Drop Ratings:

The pressure drop data shown below is based on laboratory conditions. The test setup does not take into account elbows or other duct fittings that are part of every actual duct system. The configuration of the actual duct system immediately upstream and downstream of the damper often contributes more pressure loss than the damper itself.

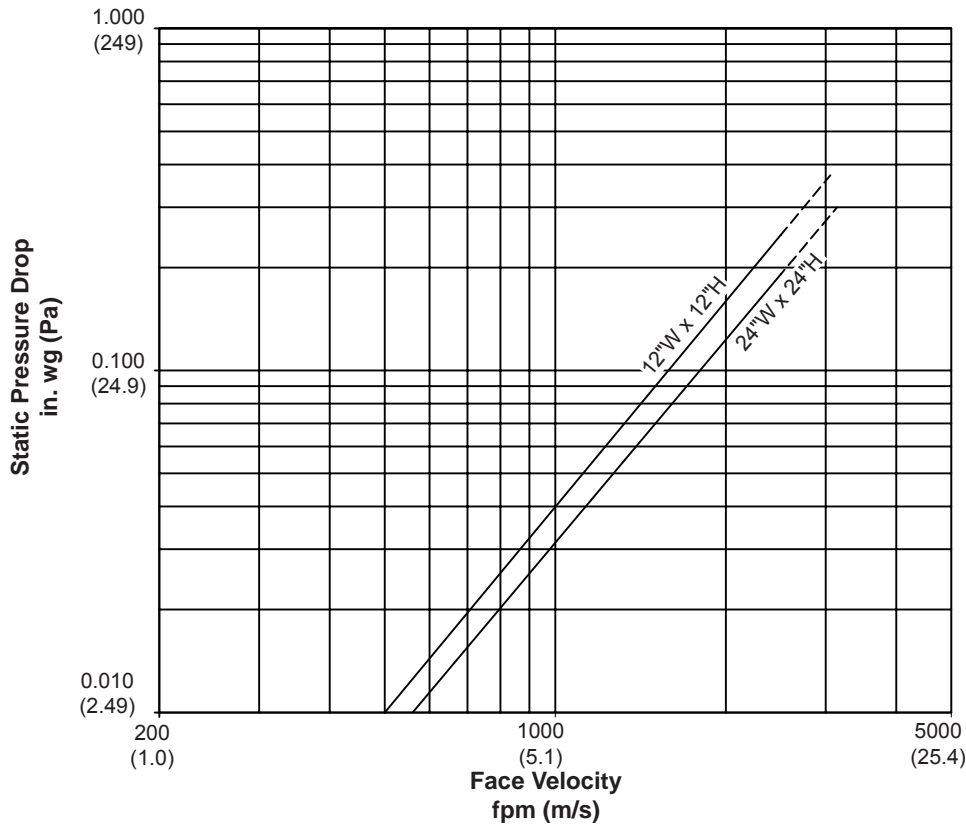

AMCA Figure 5.3



Air Balance Inc. certifies that the model SR2 damper shown here is licensed to bear the AMCA seal. The ratings shown are based on tests and procedures performed in accordance with AMCA Publication 511 and comply with the requirements of the AMCA certified Ratings Program. The AMCA Certified Ratings Seal applies to Air Performance Ratings only.