

# MODEL BS55

4" Deep • Single Thickness Blade • -40°F to 190°F Temperature • Aluminum Backdraft Damper

## STANDARD MATERIALS AND CONSTRUCTION

- FRAME:** .081" thick 6063-T6/T52 extruded aluminum alloy;  
1" x 4" x 1" channel frame on all sides
- BLADES:** .081" thick 6063-T6/T52 extruded aluminum alloy, designed for strength and low leakage with overlapping edges
- SHAFTS:** ½" dia. extruded aluminum pin-lock design
- BLADE SEALS:** Silicone rubber off-set leg
- BEARINGS:** Celcon bearing material so that there will be no metal to metal friction
- LINKAGE:** Face mounted in the airstream
- FINISH:** Mill
- TEMP. LIMITS:** -40°F to 190°F

## OPTIONS

- Aluminum (1 5/8" x 6" x 1 5/8") Frame
- Flanged (2" x 4" x 5/8") Frame
- Steel (Channel or Flange) Frame
- Variety of Bird or Insect Screens
- Linkage Out of Airstream
- Polyurethane or Neoprene Jamb Seals
- Oilite Bronze or Ball Bearings
- Counterweights

## NOTES

1. "A" width and "B" height are opening dimensions. Dampers are provided by inside dimension.
2. Counterweights are adjustable for infinite opening pressures. Optional locations. Specify if airstream is horizontal, vertical up or down. Specify to assist or resist opening. Specify locations internally (on blades) or externally (on external shaft).
3. When a non-symmetrical frame cross section is specified (example: flange frame) specify the flange/airflow orientation.
4. Approximate damper weight is 6 ½ lbs/sq.ft.

## DAMPER SIZES

Panels	Min Panel	Max Single Panel
BS55	8"W x 8"H	48"W x 72"H

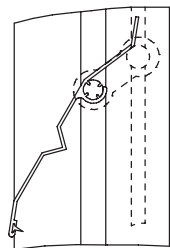
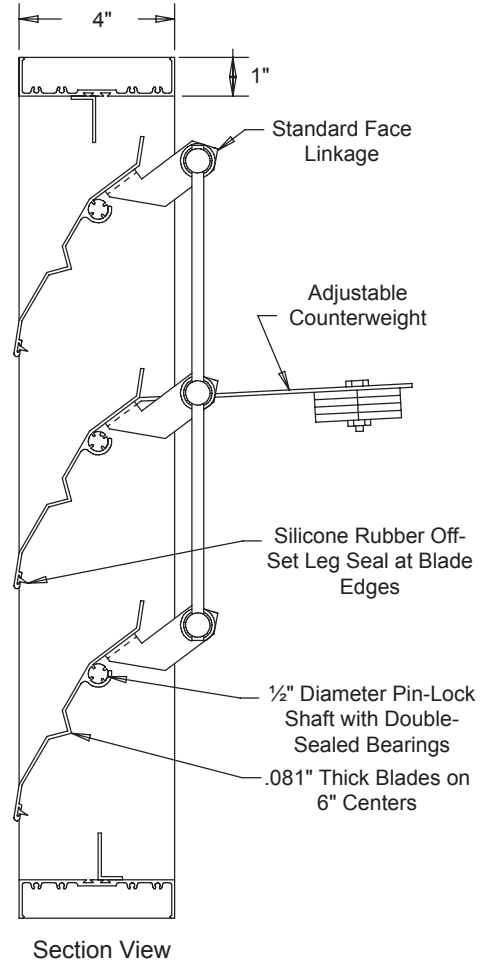

Optional Jamb Linkage and Jamb Seals

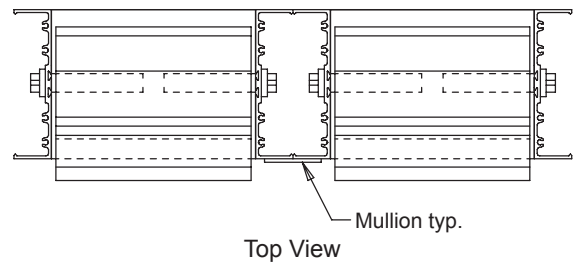

# MODEL BS55

4" Deep • Single Thickness Blade • -40°F to 190°F Temperature • Aluminum Backdraft Damper

Typical performance for model BS55 Backdraft Damper. Size tested 42"W x 42"H, furnished with counterweight to assist opening.

**Without Ductwork**

Damper installed per AMCA 500 Fig. 5.4 (Face Mounted to a Plenum). Pressure is corrected to .075 lb./cu.ft. air density.

Operational Pressures  
Start to Open - .01 in.wg  
Fully Open - .52 in.wg

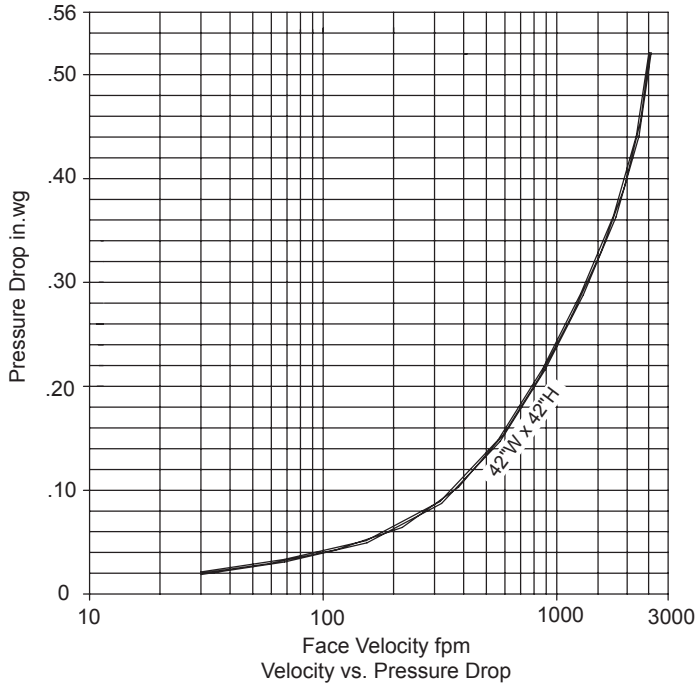

**With Ductwork**

Damper installed per AMCA 500 Fig. 5.3 (Ductwork installed upstream and downstream of damper). Pressure is corrected to .075 lb./cu.ft. air density.

Operational Pressures  
Start to Open - .01 in.wg  
Fully Open - .18 in.wg

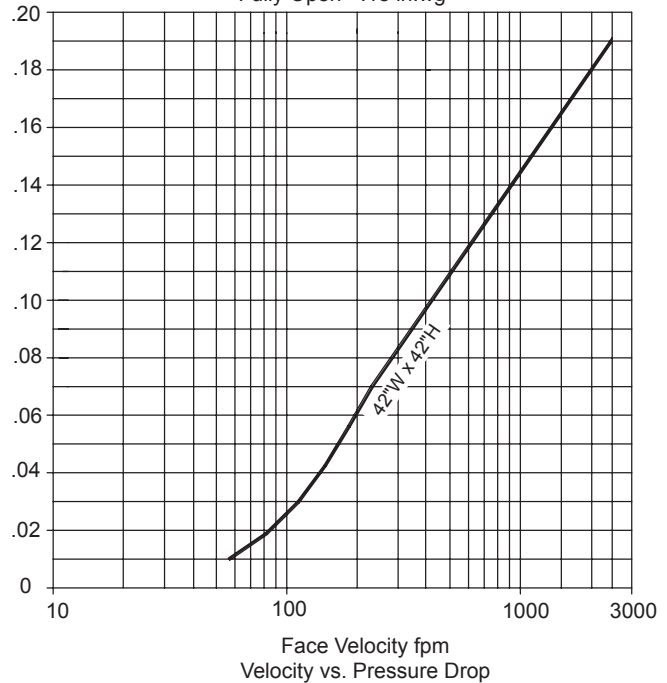

**Air Leakage:**

Air leakage quantities shown in the chart are results of tests per AMCA standard 500 and are shown at .10 inwg differential pressure and corrected to .075 lb./cu.ft. air density.

Total CFM Air Leakage at .10" Static Pressure Differential Through Closed Damper

		Width						
		12	18	24	30	36	42	48
Height	12	3.0	4.5	6.0	7.5	9.0	10.5	12.0
	24	6.0	9.0	12.0	15.0	18.0	21.0	24.0
	36	9.0	13.5	18.0	22.5	27.0	31.5	36.0
	48	12.0	18.0	24.0	30.0	36.0	42.0	48.0
	60	15.0	22.5	30.0	37.5	45.0	52.5	60.0
	72	18.0	27.0	36.0	45.0	54.0	63.0	72.0

For determining leakage values greater than .10 in.wg to a maximum 4 in.wg use the multiplier correction chart below.

Static Pressure (in)	.2	.3	.4	.5	1.0	2.0	3.0	4.0
Multiplier Correction Factor	1.7	2.0	2.3	2.7	4.0	5.0	6.7	8.3

Air leakage ratings are based on AMCA standard 500 using test set up Fig. 5.4 with damper in the closed position without the aid of a counterweight or other mechanical means to provide closing torque. For a size 42"W x 42"H damper with blade and jamb seals.