

Electric Sensotherm (ESOT)

Combination Fire/Smoke Damper

Application

The Electric Sensotherm (ESOT) is a packaged combination of two heat sensing, bi-metallic disc type switches of different temperature ratings and a blade position indicator. Upon exposure to elevated temperature, the lower temperature rated thermal disc mechanically opens the electric circuit and interrupts the power supply to the actuator, thus causing the actuator's internal spring to drive the damper to the closed and locked position. The blade position indicator will provide feedback to an installer-supplied controls system that the damper is closed. When necessary, an installer-supplied three position Master Control Switch (MCS) can be used to redirect power from the open lower temperature rated thermal disc to the closed higher temperature rated thermal disc, thus re-opening the damper to purge smoke or pressurize zones surrounding the fire incident area. If the temperature conditions again raise to elevated levels, the higher temperature rated thermal disc will open and the damper will re-close to maintain the integrity of the fire barrier.

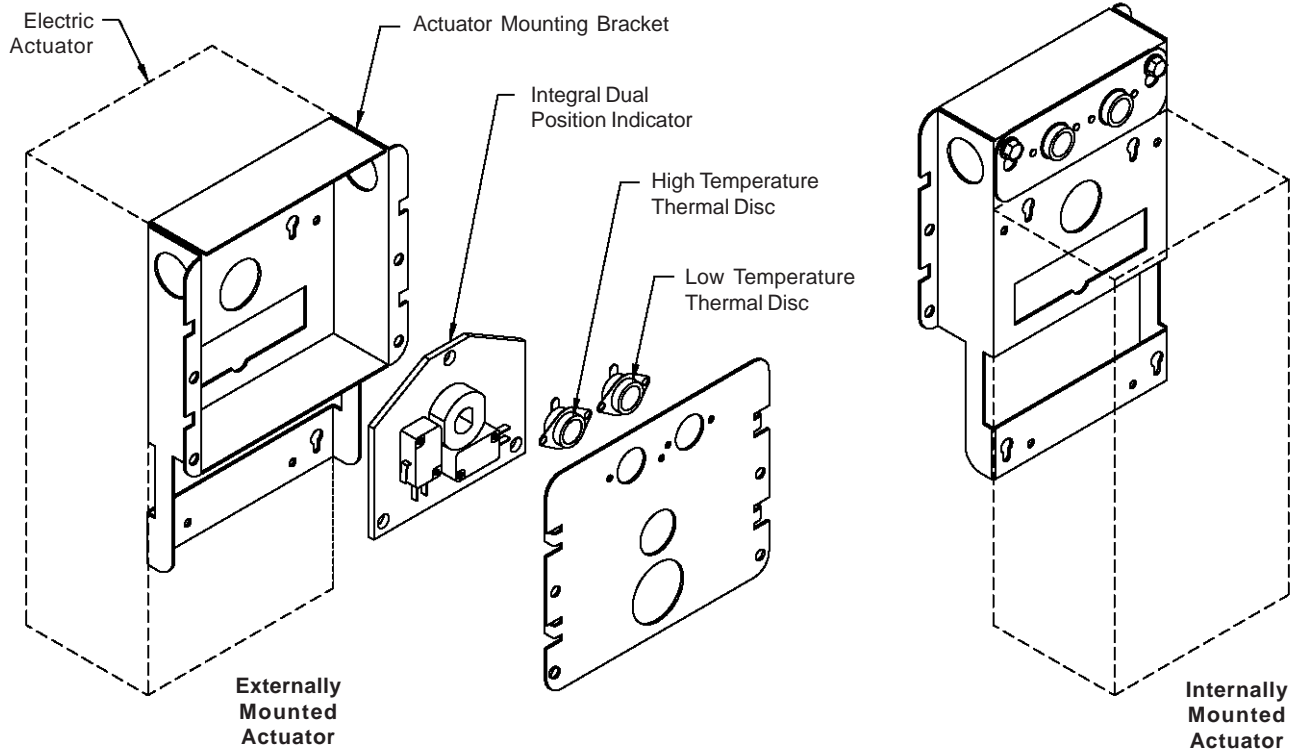

Notes

1. All wiring to be done in accordance with N.E.C. (NFPA 70).
2. Switches are rated at 1/3 HP, 125 VAC.
3. Low temperature thermal discs are available in 165°F and 212°F temperature ratings. High temperature thermal discs are available in 250°F and 350°F temperature ratings (the high temperature thermal disc rating cannot exceed the temperature rating of the damper).
4. Upon cooling, the thermal disc switches remain open and the damper remains in the closed and locked position. Assuming that incident temperatures were not excessive, the damper can be re-opened by manually depressing the reset buttons on the back of the thermal discs. Prior to resetting the thermal discs, the damper and it's power supply should be inspected for heat related damage.

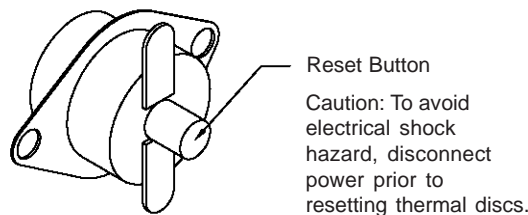

Back View of Thermal Disc

Electric Sensotherm (ESOT)

Combination Fire/Smoke Damper

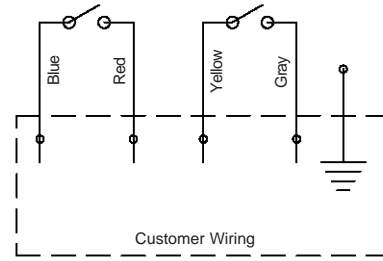
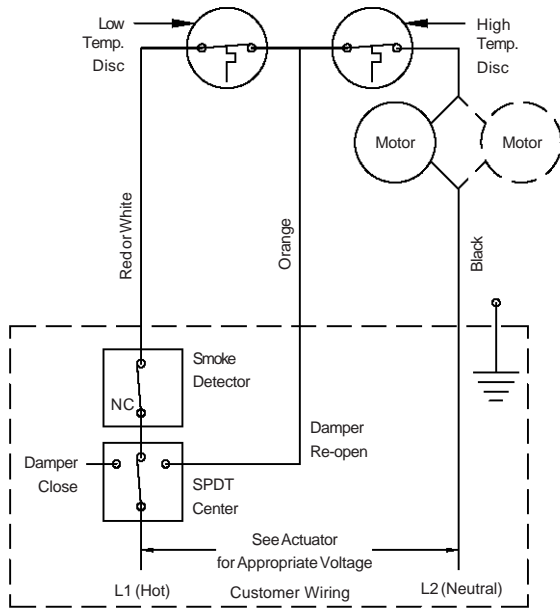

actuator mounting location	damper full open	damper full close	damper mid-stroke
	closed circuit		
external left	red / blue	yellow / gray	none
external right	yellow / gray	red / blue	none
internal left	yellow / gray	red / blue	none
internal right	red / blue	yellow / gray	none

* This wiring is opposite if the actuator is rotated 90°, so that it is parallel to the duct..

ESOT/PSOT Wiring, Test, and Operating Instructions

Damper is supplied with one low temperature thermal disc and one high temperature thermal disc. All dampers require a master control switch (supplied by others) for re-openable operation.

CUSTOMER WIRING

1. Connect input power lead L1 from the normal closed position lead of the (MCS) switch to damper lead L1.
Note: If a smoke detector or other sensing device is to be employed, its NC contact set should be wired in series between the (MCS) position switch normal wire and lead L1.
2. Connect incoming lead L2 to damper lead L2.
3. Connect the reopen switch lead from (MCS) to orange damper lead.
4. Connect the incoming ground lead to the wiring enclosure.
5. Install IDPI (if used) per the schematic.
6. Replace enclosure cover.

CIRCUIT TEST

1. Place (MCS) switch in damper close position.
2. Apply power.
Result: The closed indicator light (if used) should be on and the damper blades closed.
3. Transfer (MCS) switch to damper re-open position.
Result: The damper blades should open; the closed indicator light (if used) should go off and the open indicator light (if used) should go on.
4. Transfer (MCS) switch to the normal position.
Result: The damper blades should remain open and the open indicator light (if used) should remain on.
5. Transfer the (MCS) switch to the closed position.
Result: The damper blades should close; the open indicator light (if used) should go off and the closed indicator light (if used) should go on.

EMERGENCY OPERATION (SMOKE MANAGEMENT)

1. **MCS closed position:** Damper will close regardless of whether the thermal switch device has activated or not and regardless of the command from the smoke system.
2. **MCS re-open position:** If the damper has not been exposed to an elevated temperature higher than its rating, the damper will open. Also, the damper will open regardless of whether the low temperature thermal disc (165°F or 212°F) has activated or not and regardless of a command from additional sensing devices, such as a smoke detector.

NOTE: If the master control switch (MCS) is in the re-open position and the high temperature thermal disc has not been tripped, the damper will remain open regardless of whether the low temperature thermal disc and/or other sensing devices have tripped or not. If the damper has been exposed to an elevated temperature higher than its temperature degradation rating, or if the electrical or pneumatic supply has been disconnected, the damper will close and remain closed regardless of any (MCS) position.