

# MODEL S480

4" Deep • Inverted "V" Blade • Formed Steel Stationary Louver

## STANDARD MATERIALS AND CONSTRUCTION

- FRAME:** 18-GA galvanized steel channel type
- BLADES:** 18-GA galvanized steel
- BLADE SPACING:** 3"
- ASSEMBLY:** Riveted and/or welded for maximum service
- FINISH:** Mill
- SCREEN:** ½" mesh 19-GA galvanized

## OPTIONS

- Flange Frame
- Extended Sub-Sills (3" or 5")
- Sub-Frame
- Installation Angles
- Stainless Steel, Copper, Aluminum, Other Steel Gauges
- Finishes - Baked Enamel, Epoxies
- Variety of Bird and Insect Screens
- Blank-Off Panels

## NOTES

1. "A" width and "B" height are opening dimensions. Louvers are provided approximately ½" undersize.
2. Approximate louver weight is 10 lbs./sq.ft.

## LOUVER SIZE

Panels	Minimum Panel	Maximum Panel
S480	12"W x 12"H	60"W x 96"H

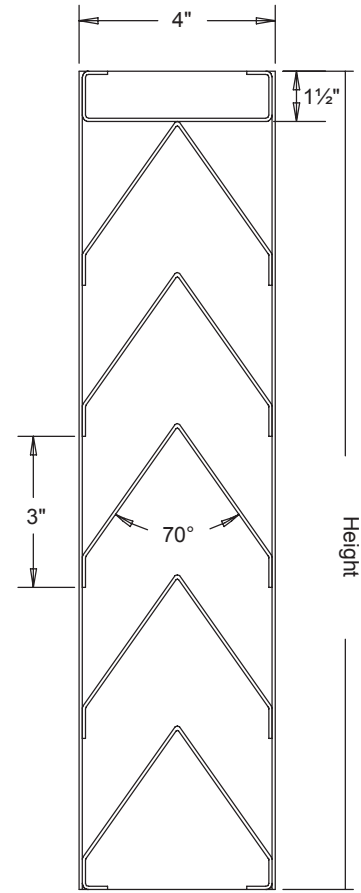

Section View



Optional Flange Frame

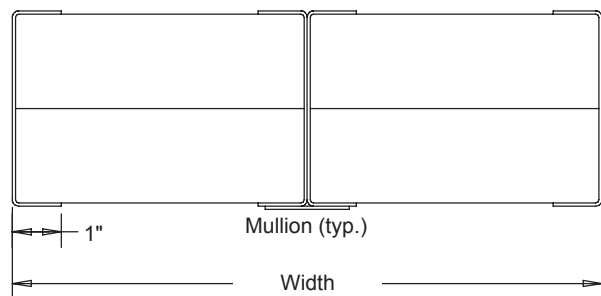

Mullion (typ.)

Width  
Top View

# MODEL S480

4" Deep • Inverted "V" Blade • Formed Steel Stationary Louver

This page intentionally left blank.